

F o r m a l L i t e r a c y

I D Y E A R 2 2 0 0 9

Frank Gehry & Jess Maertterer

mARTa Herford Germany

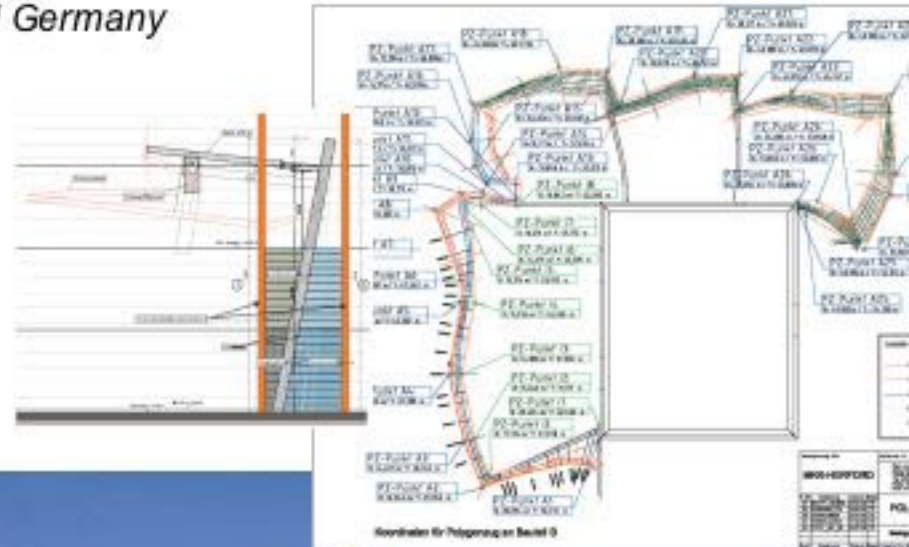



Santiago Calatrava

$$D = \frac{1}{c} \frac{1}{l} \frac{dl}{dt} = \frac{1}{c} \frac{1}{P} \frac{dP}{dt}$$

$$D^2 = \frac{1}{P^2} \frac{P_0 - P}{P} \sim \frac{1}{P^2} \quad (1a)$$

$$D^2 = \frac{\kappa \rho}{3} \frac{P_0 - P}{P_0} \sim \kappa \rho \quad (2a)$$

$$D^2 \sim 10^{-53}$$

$$\rho \sim 10^{-26}$$

$$P \sim 10^8 \text{ g/cm}^3$$

$$\kappa \sim 10^{10} (10^{11})$$

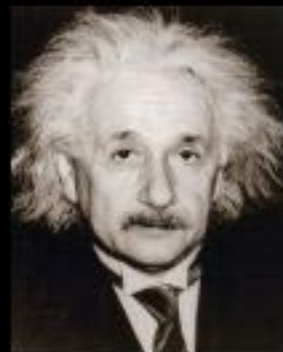

Einstein

Mathematics Geometry and Aesthetics

Einstein*mathematics is the search for the abstract*

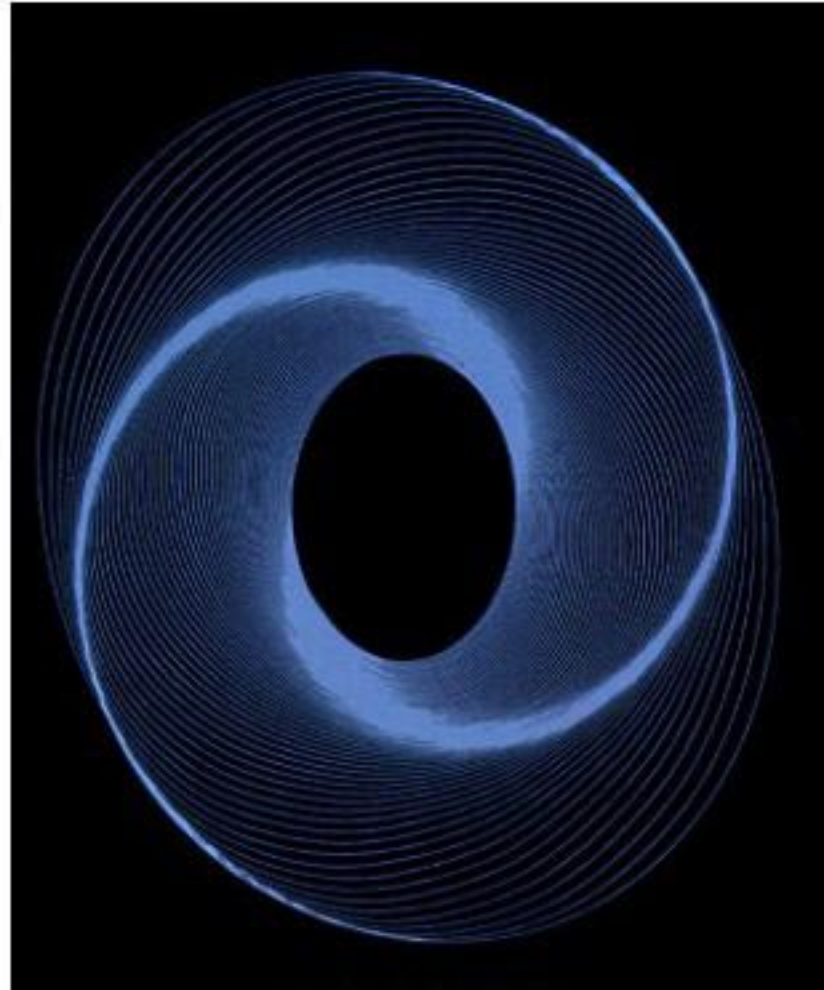

Theory of relativity (1905)



Le Corbusier

Chapel, France 1950

Sofa lc2 1929

Villa Savoye, Poissy, France 1929



Mathematics Geometry and Aesthetics

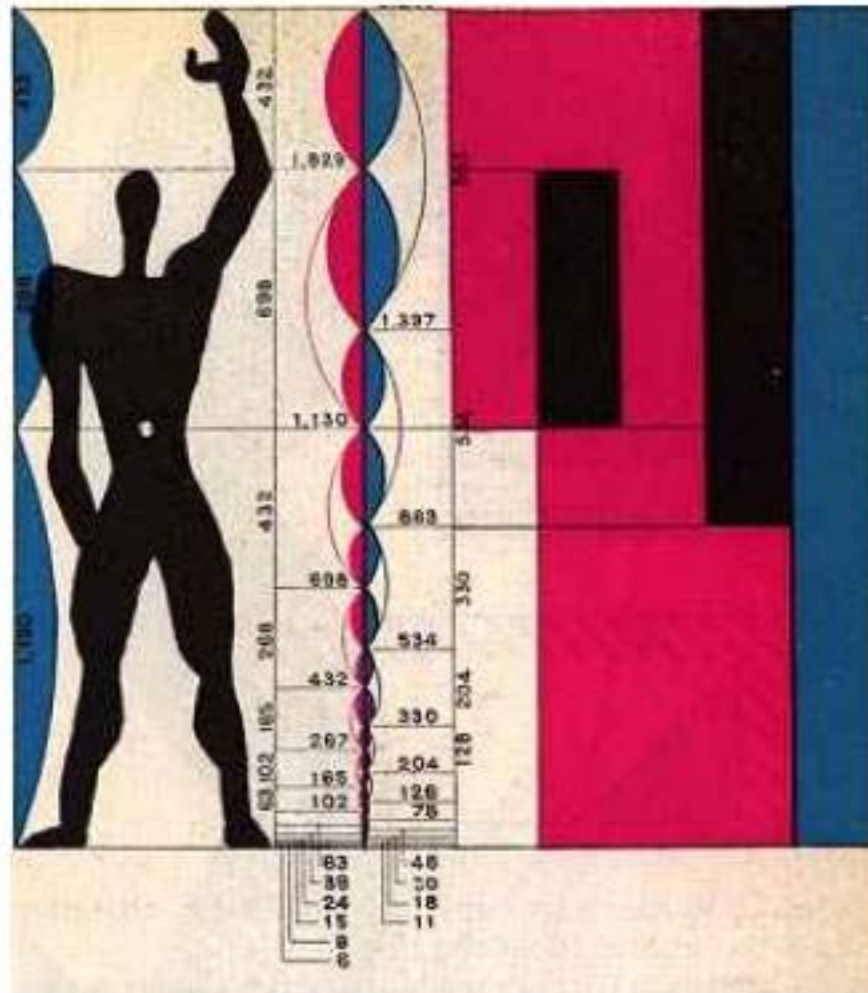

Le Corbusier 'good design is to be found in the search for mathematical order' **Le Modulor** (1948)

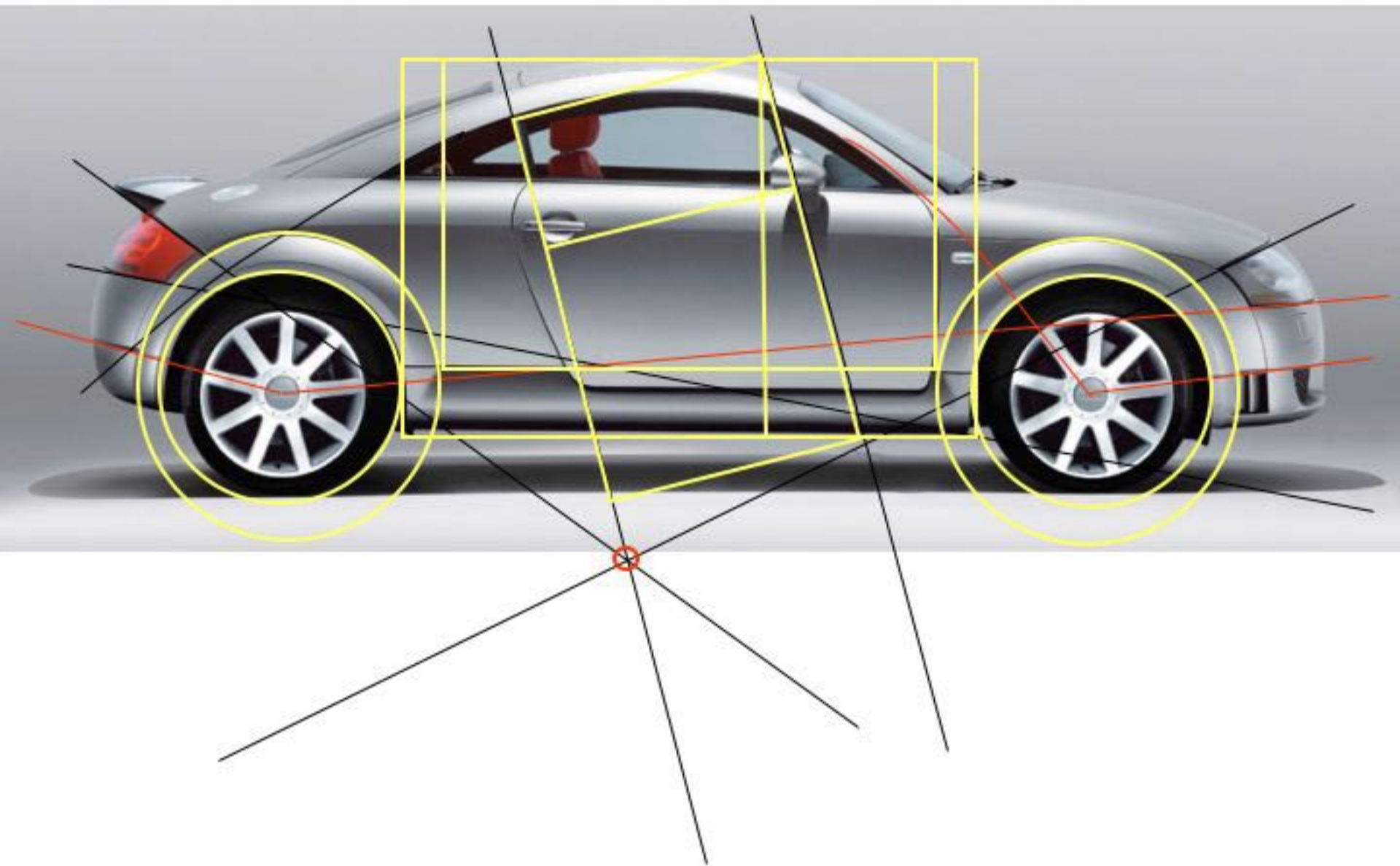

Geometry and Aesthetics



Walter de'Silva

- Simple
- Rational
- Precise
- United
- Emotion



Audi TT 2007

BMW Concept Coupé Mille Miglia 2006

- Emotion
- Tension
- Passion

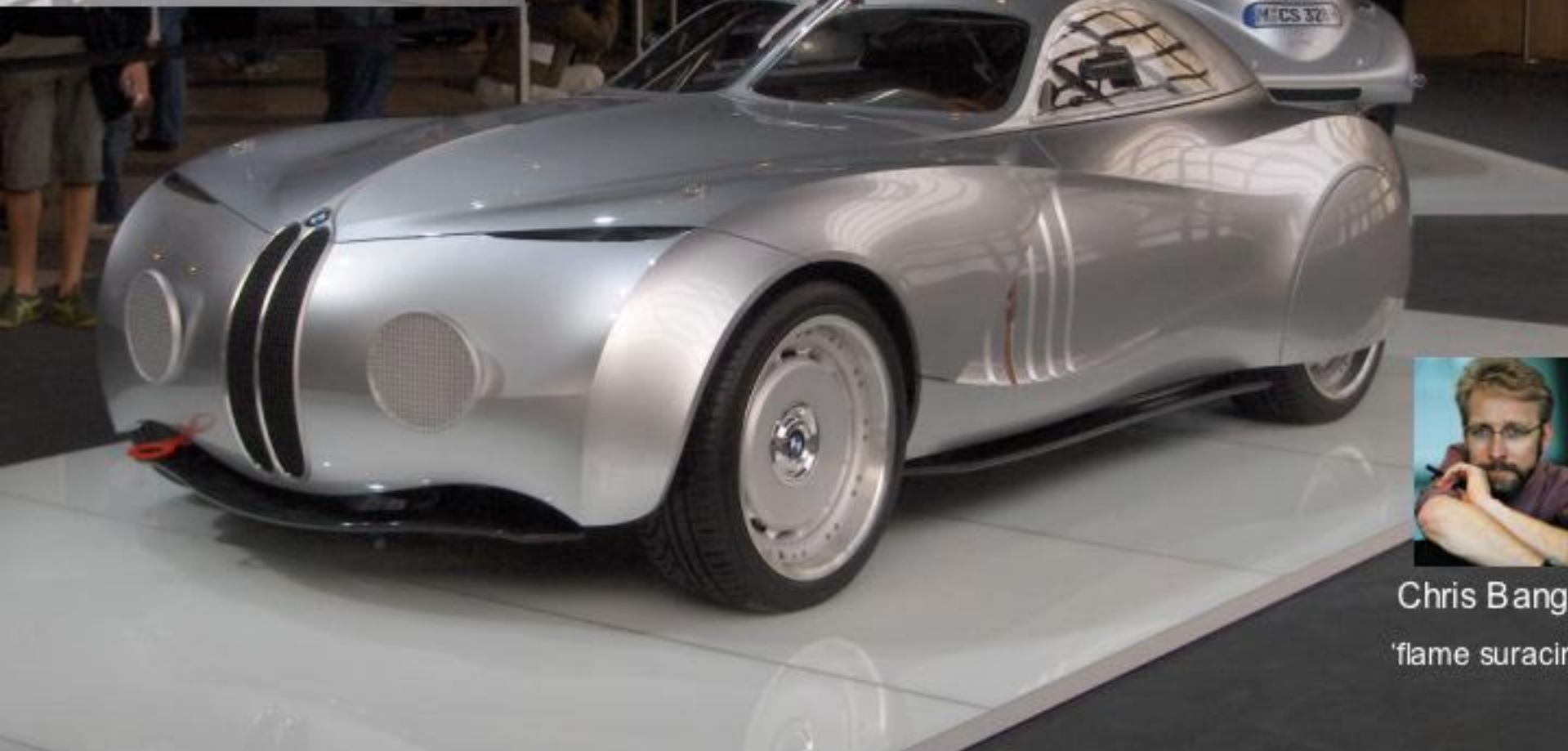

Chris Bang

'flame suracir



Anders Warming

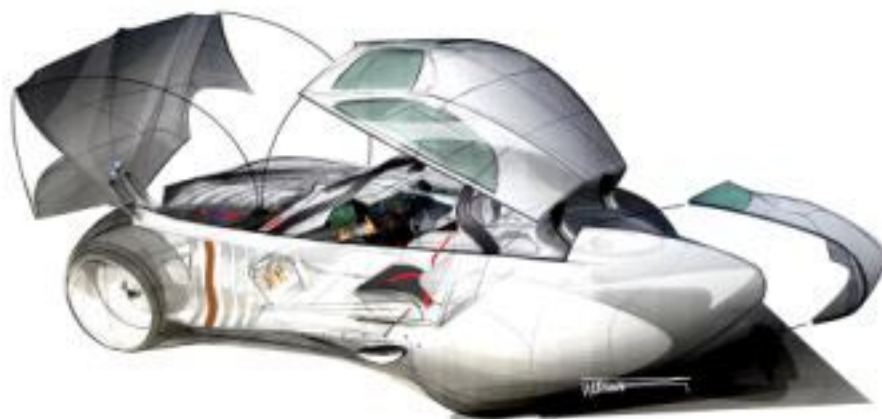



The vocabulary and language of form and function in design



BMW GINA 2008





BMW GINA 2008





Richard Saper 1972



Ross Loegrove 2002





Braun Radio

Deiter Rams

- Order
- Harmony
- Economy



1959

Apple iPod

Jonathan Ive

- Minimal
- Simple – ‘real simplicity’



COURTESY OF APPLE

2001





Apple iPhone (2007)

Proportion

Golden Section – Ratio 1:1.618

The Divine Proportion:



$$\frac{AB}{AC} = \frac{AC}{CB}$$

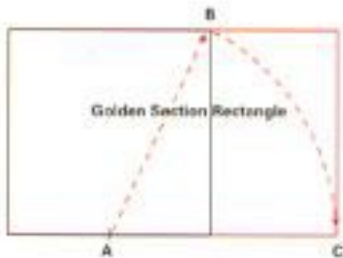

Golden Section Spiral
Construction diagram of
the golden section rectan-
gle and resulting spiral.

Chambered Nautilus

Cross section of the Nautilus'
spiral growth pattern.



Atlantic Sundial Shell
Spiral growth pattern.



Moon Snail Shell
Spiral growth pattern.

Comparison Graph of Rectangle Preference

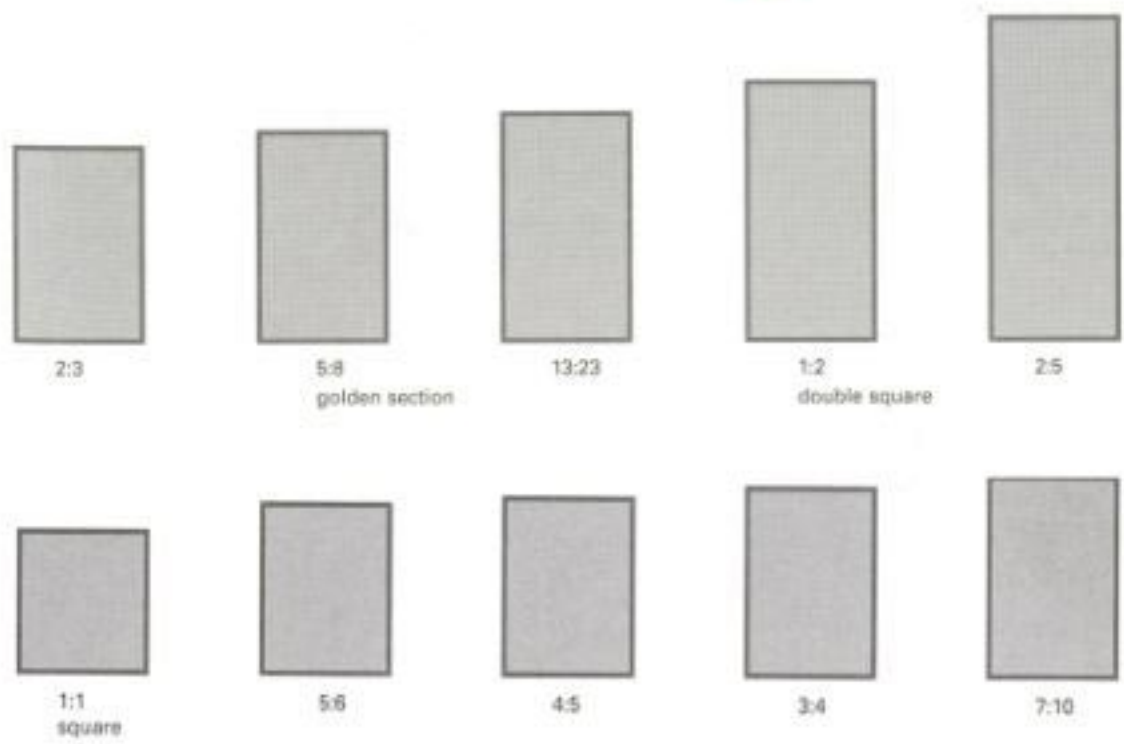
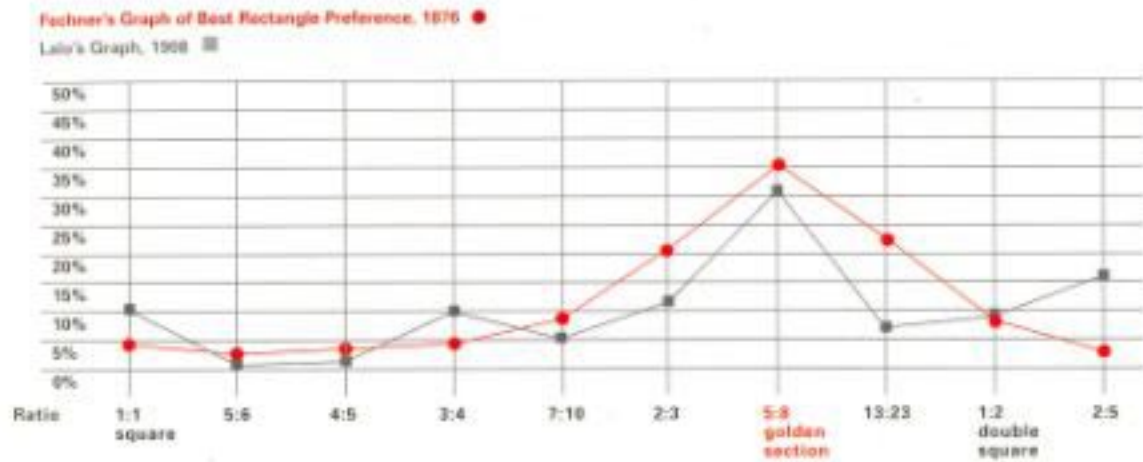



The Divine Proportion:



$$\frac{AB}{AC} = \frac{AC}{CB}$$

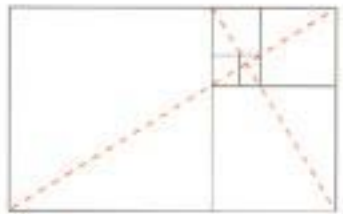
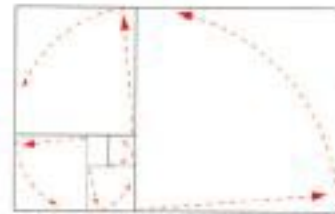
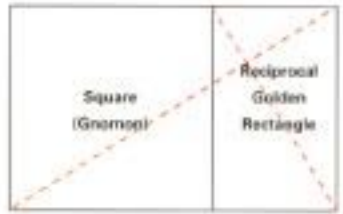
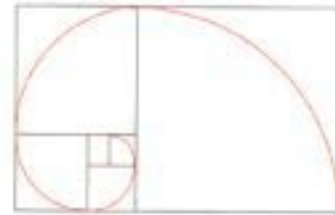
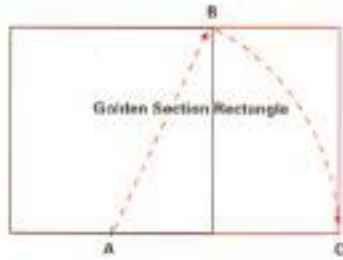
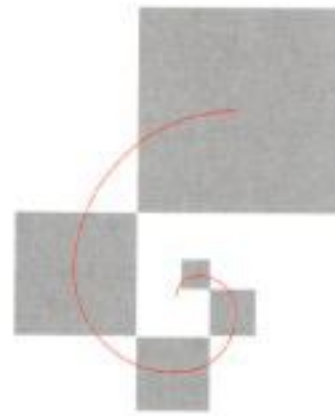

**Comparison of Tibia Shell Spiral
Growth Pattern and Golden Section
Proportion**

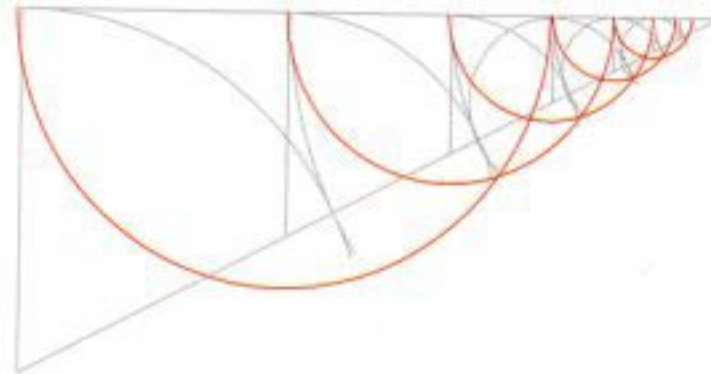

Pentagon Pattern

The pentagon and star pentagon have golden section proportions, as the ratios of the sides of the triangles in a star pentagon is 1:1.618. The same pentagon/pentagram relationships can be found in the sand dollar and in snowflakes.

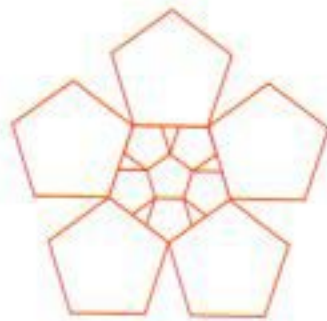

Parthenon Athens – Golden Section

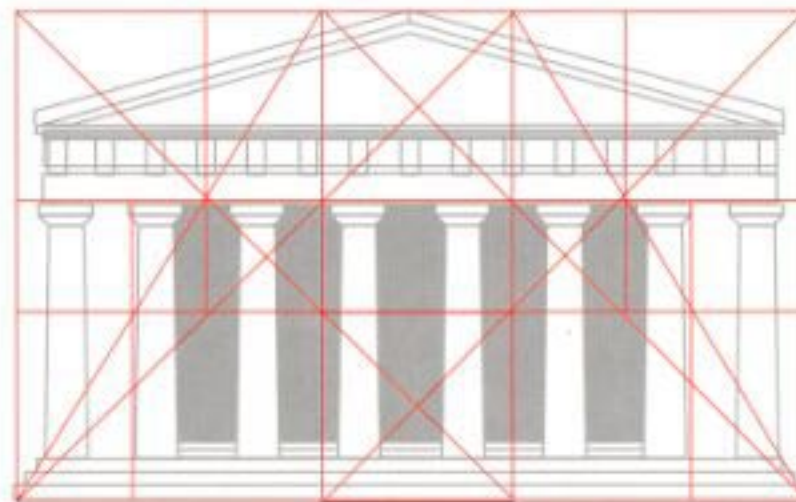
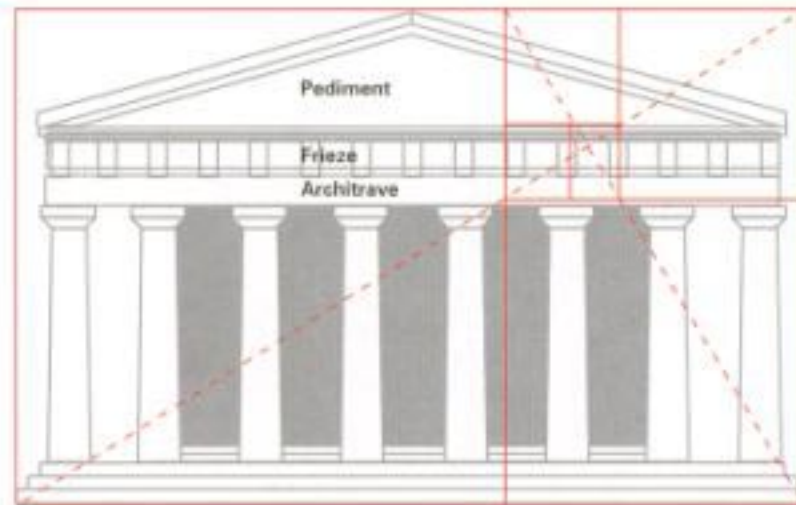

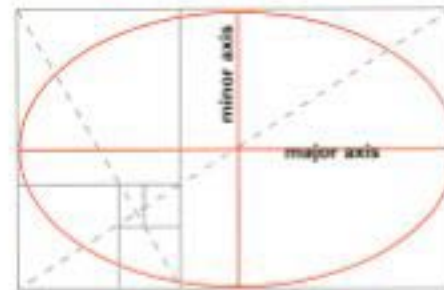
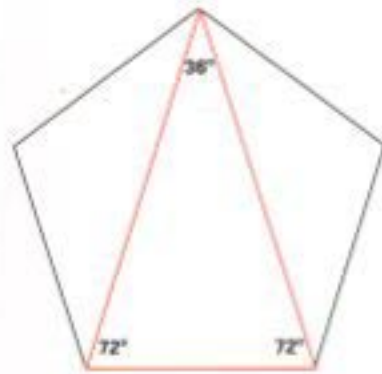

Golden Section Ellipse Inscribed Inside a Golden Section Rectangle

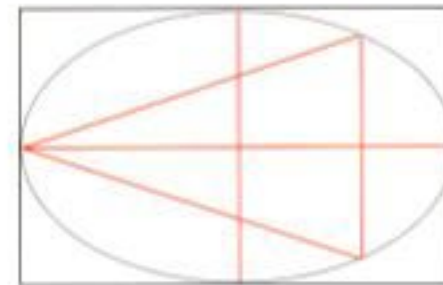
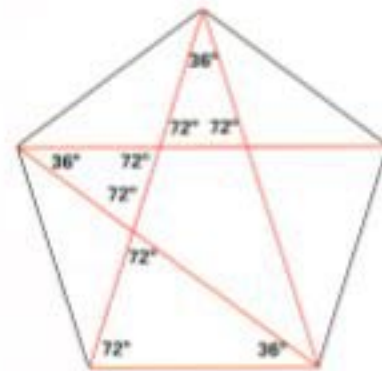

Golden Section Triangle Inscribed in a Golden Section Ellipse, Inscribed in a Golden Section Rectangle



Zeus Sculpture – Golden Section

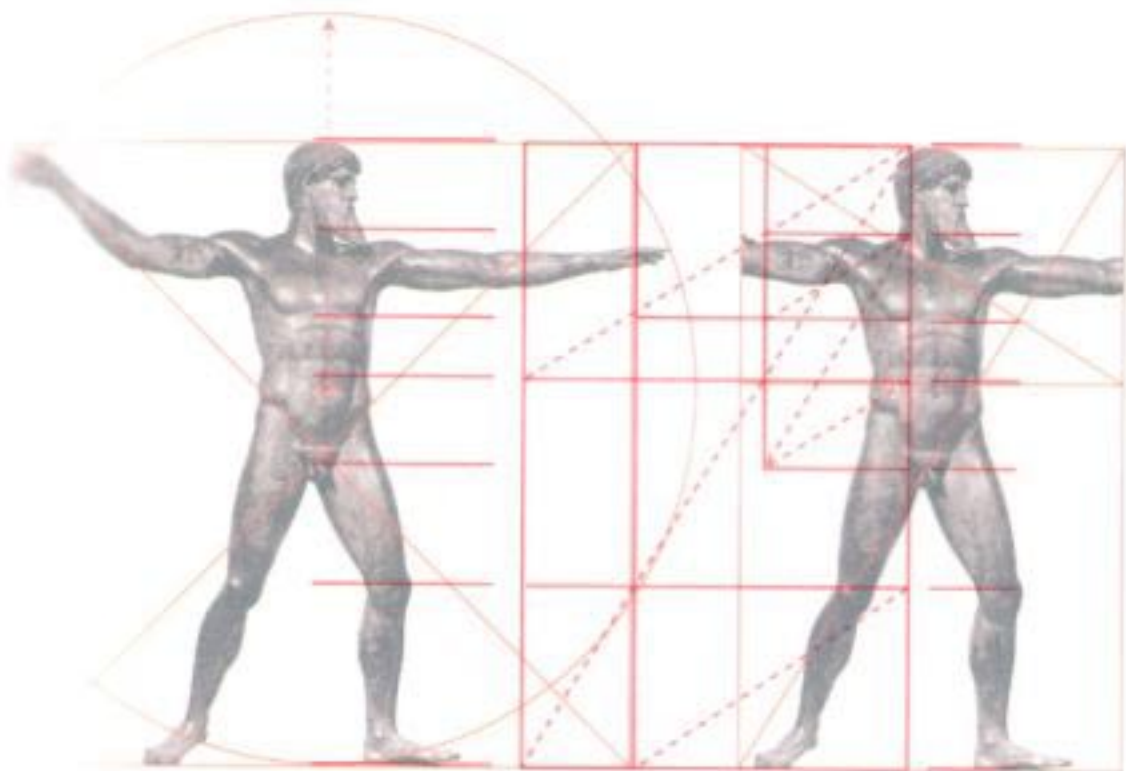

Leonardo da Vinci – Golden Section

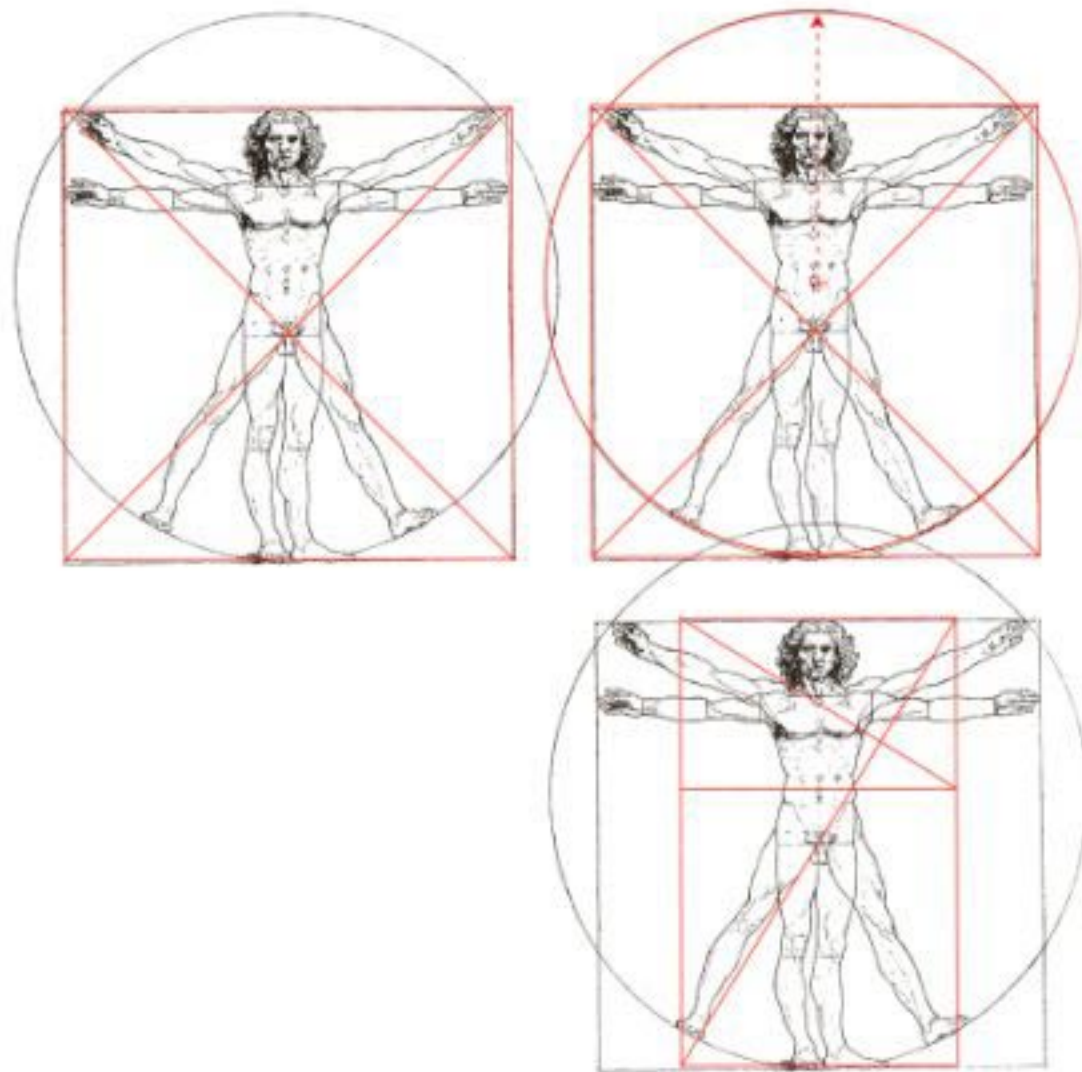

Notre Dame Cathedral Paris – Golden Section

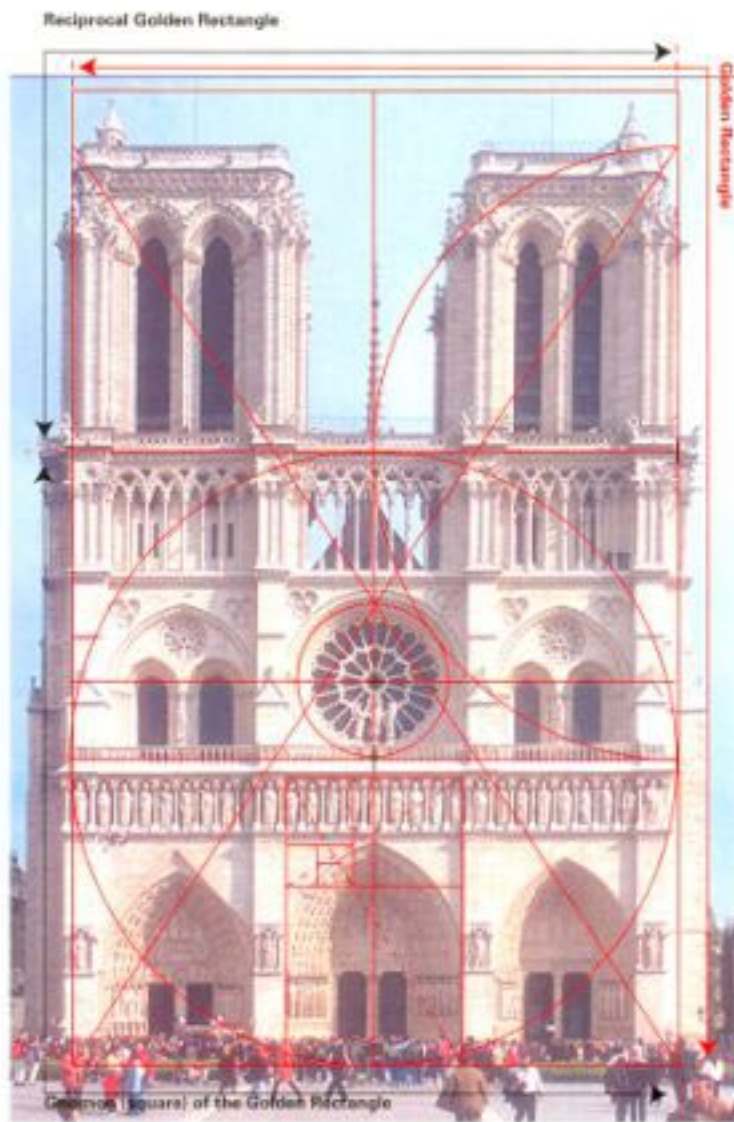



$$a - b = 1.618$$

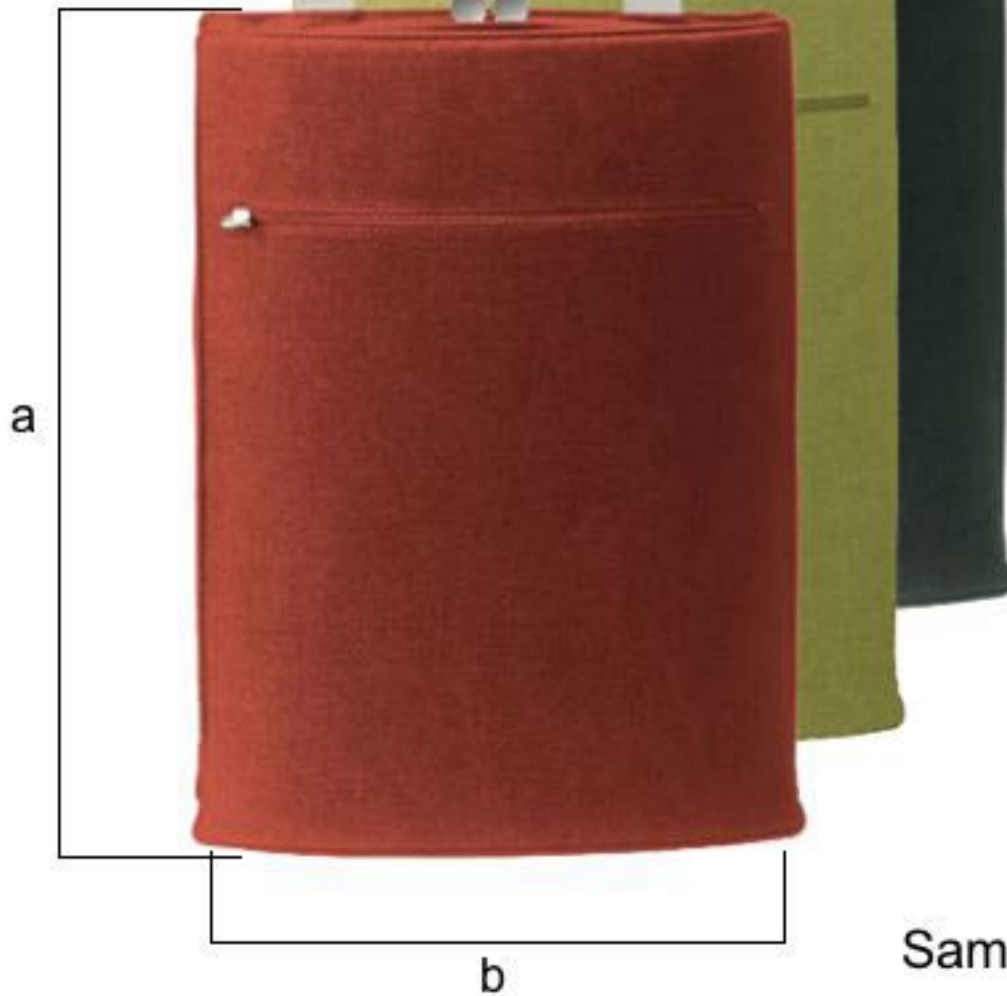

Samsonite – Laptop Backpack (2004)



Credit Cards 96mm x 54mm



National
Geographic Logo

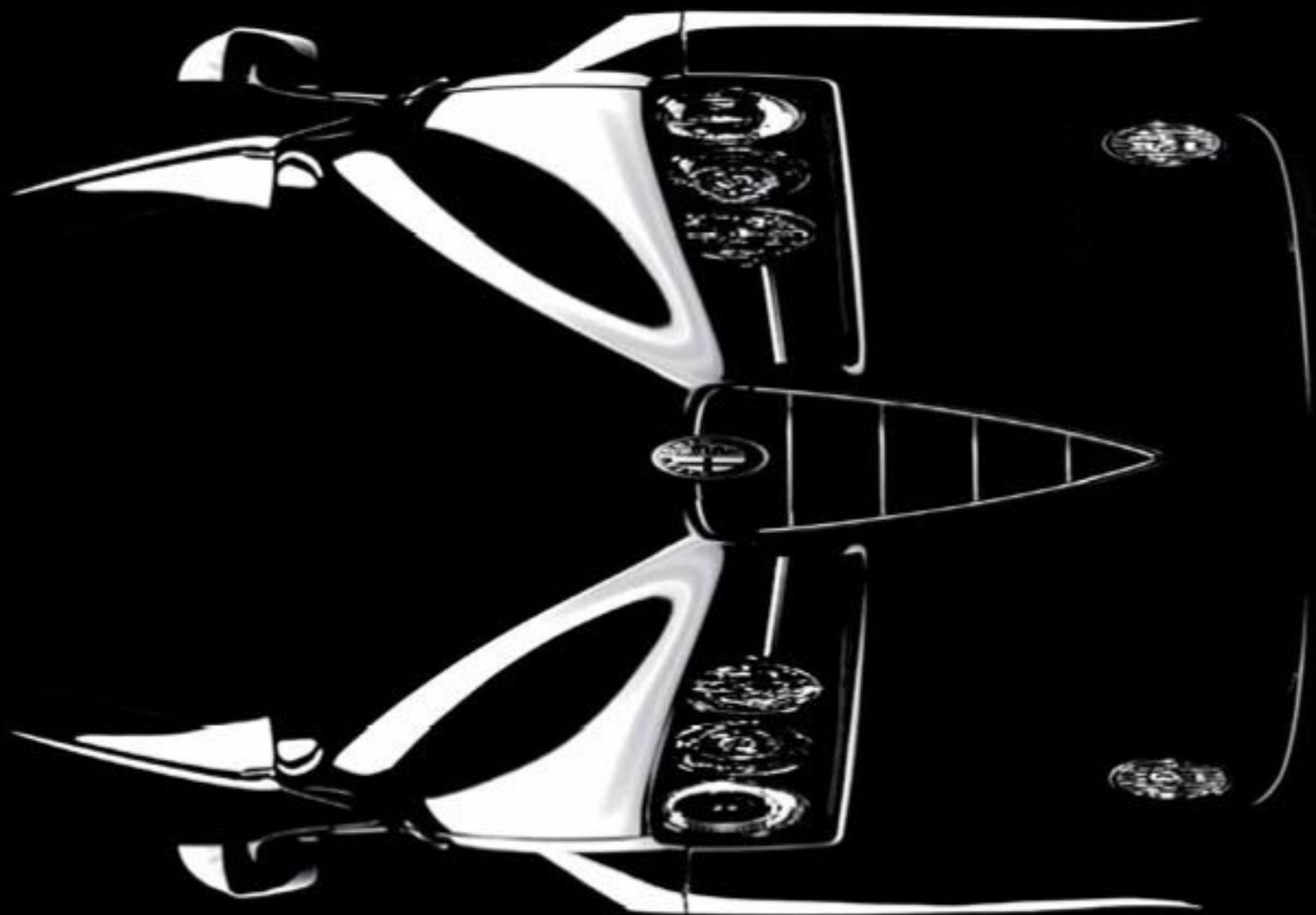

Formal Literacy

YEAR 2 2009

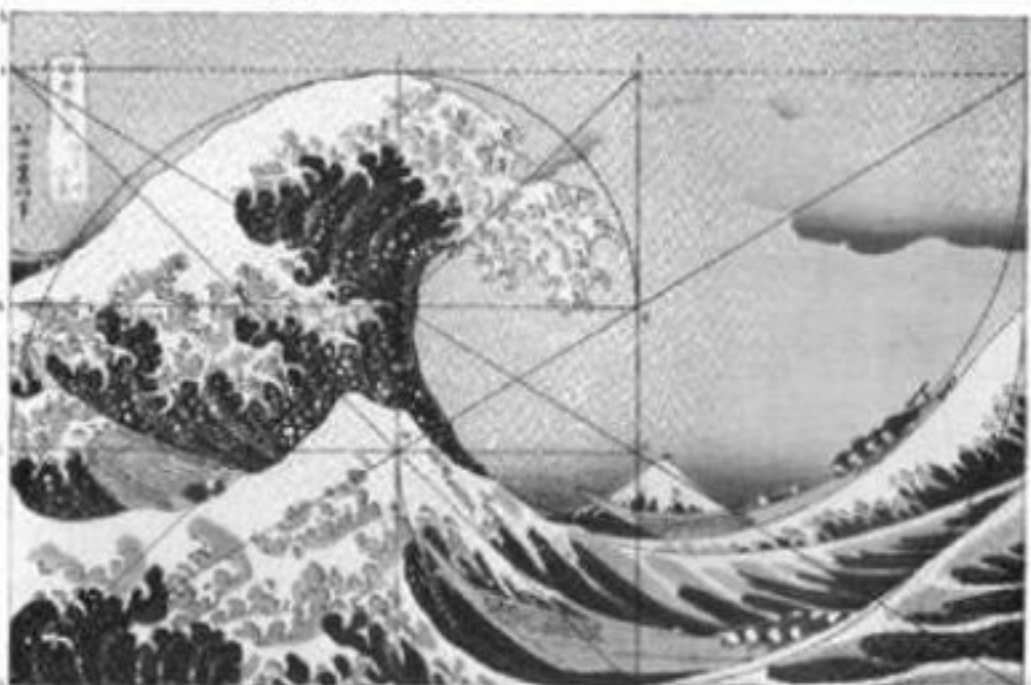

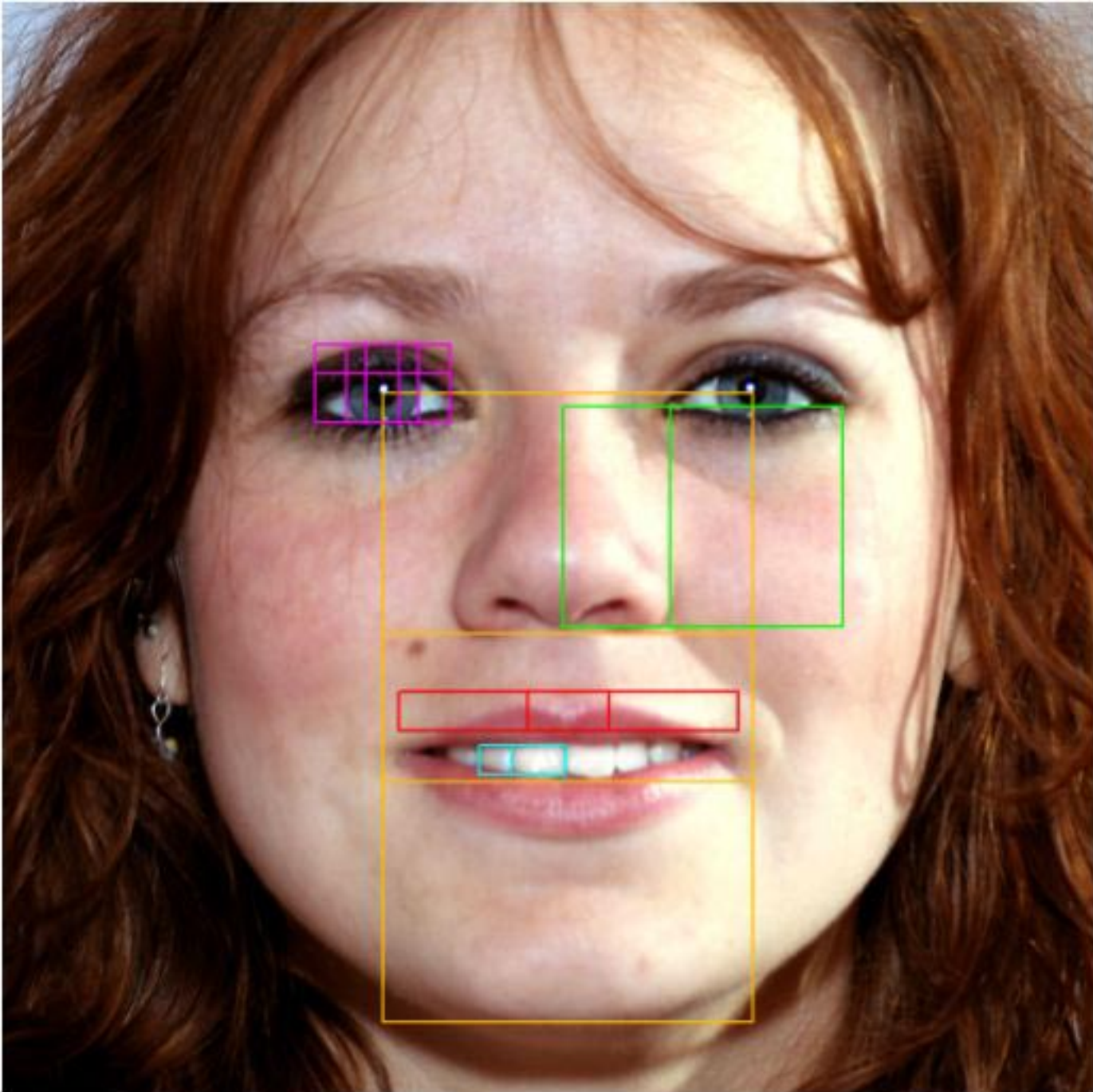

Root 2 and 3 Rectangle

Silver Rectangle

Root 2 or A4

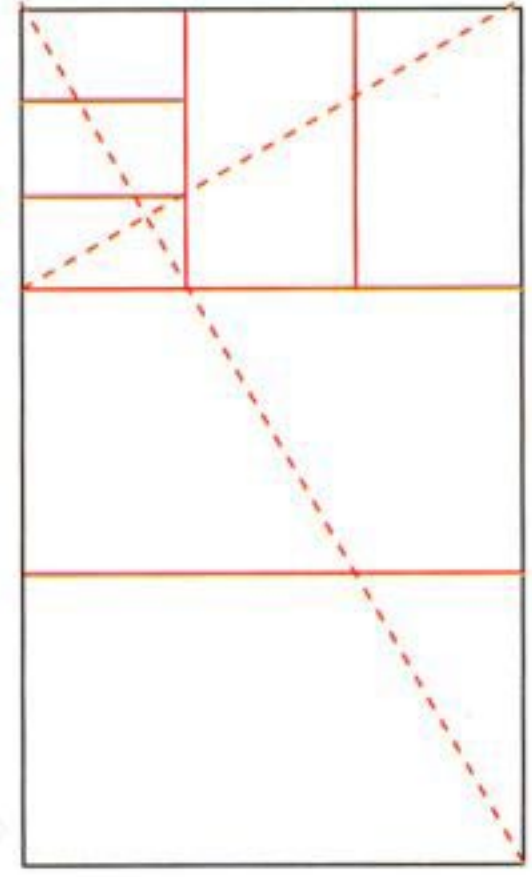
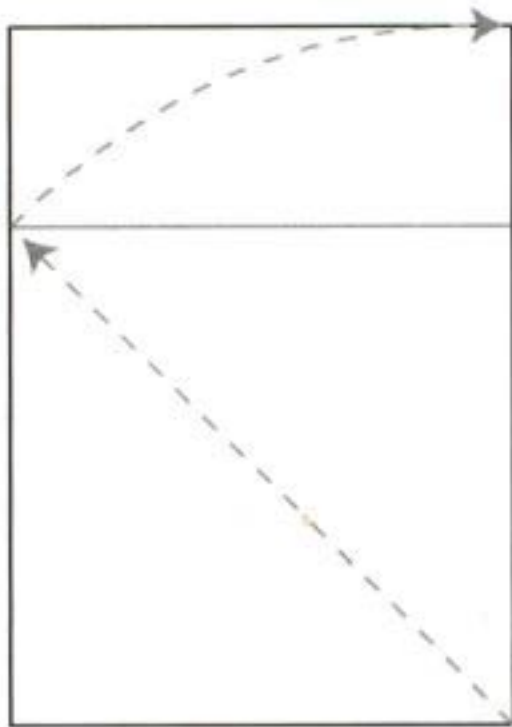

Root 2 Rectangle – A4

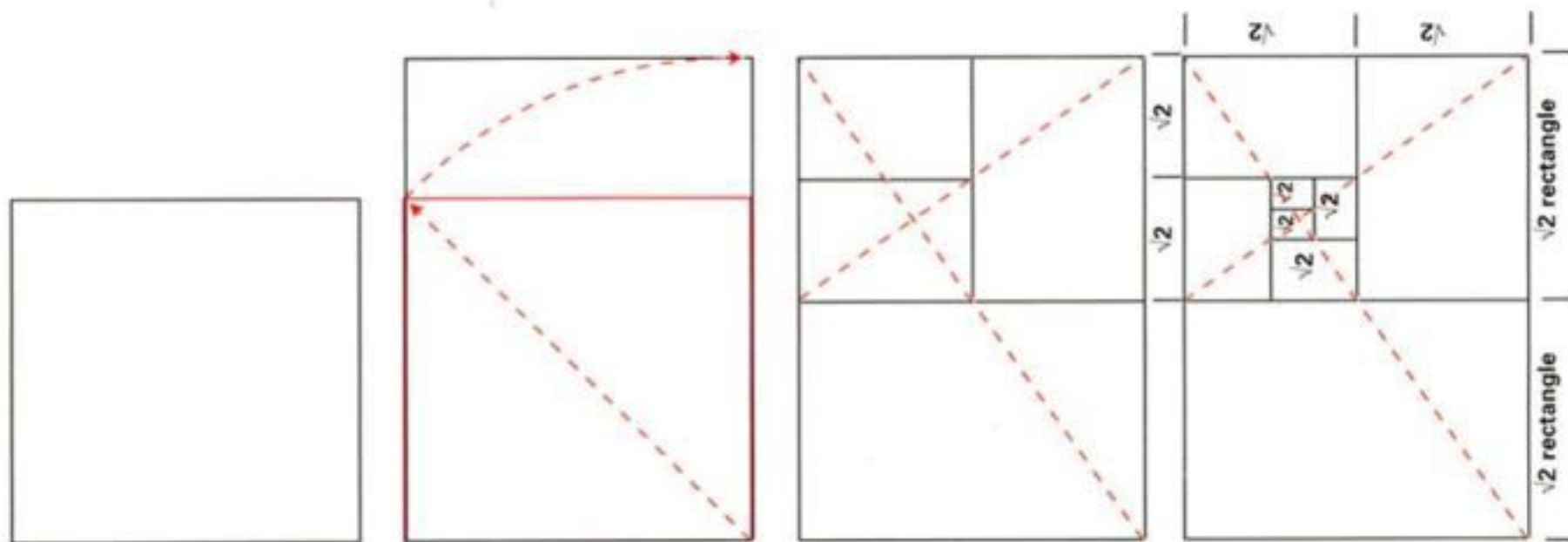

Root 3 Rectangle

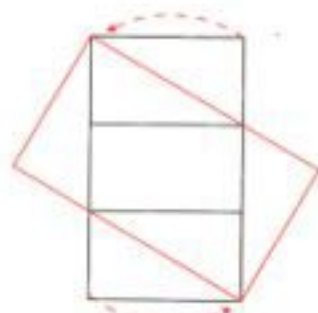

Hambridge Rectangles

HAMBIDGE RECTANGLES

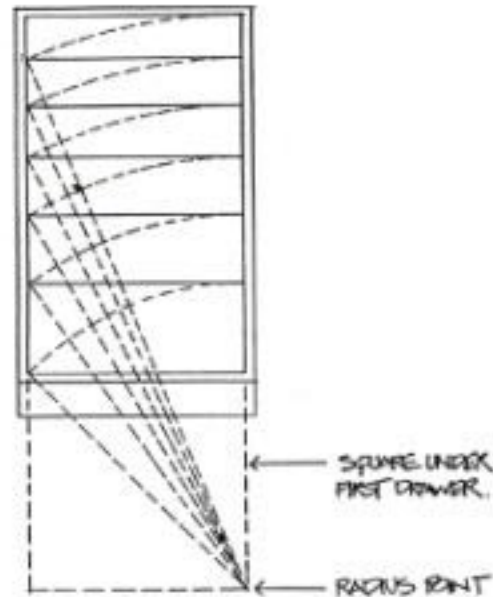
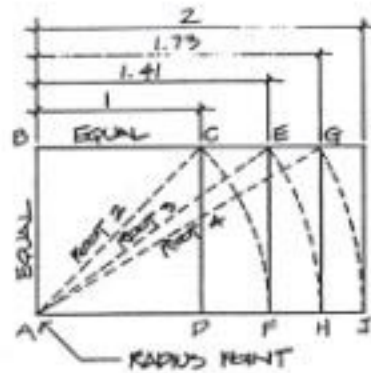

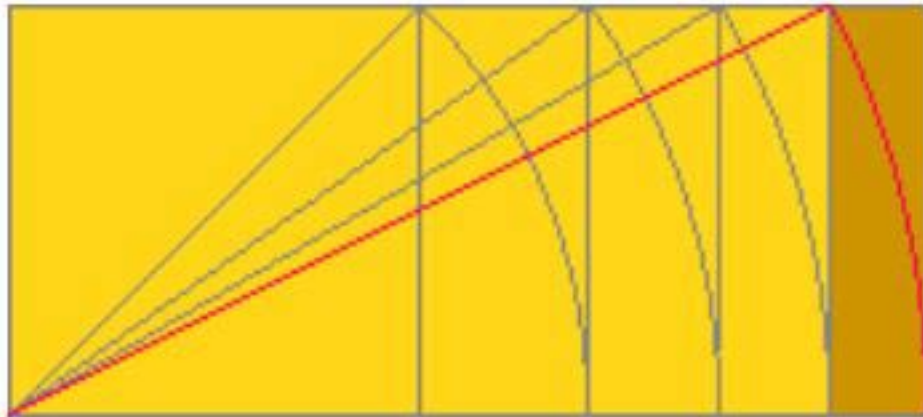

The Root 5 Rectangle has
Two Golden Sections in it



A Square & Two
Golden Rectangles



The Möbius Strip



The Möbius Strip Ramsey Auditorium 1974

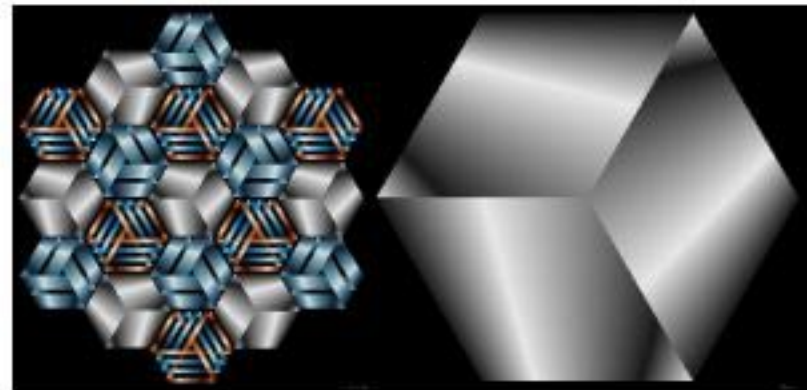

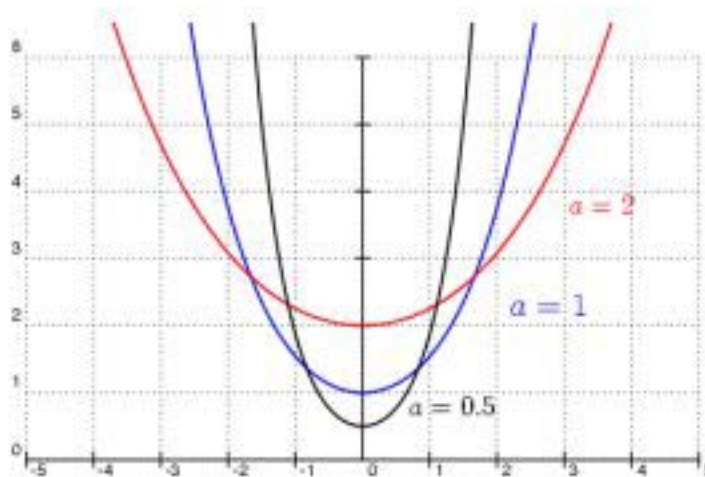
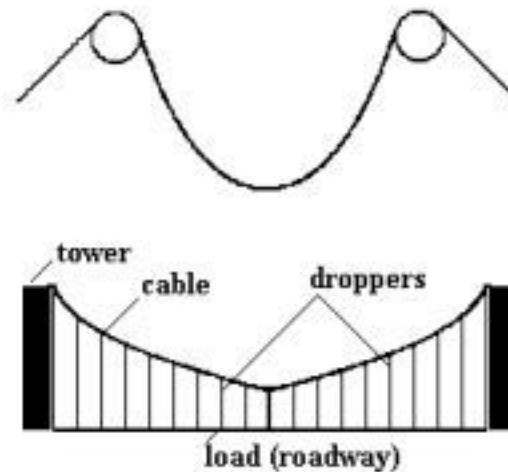

Catenary





Parabola

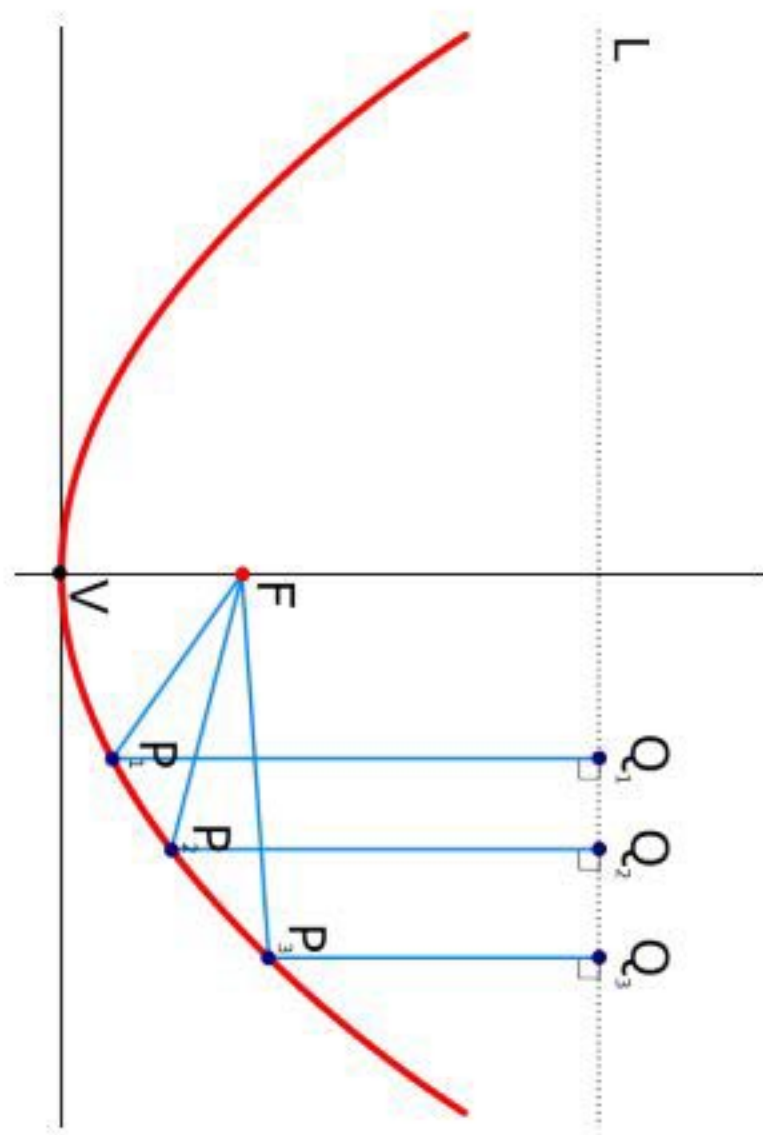



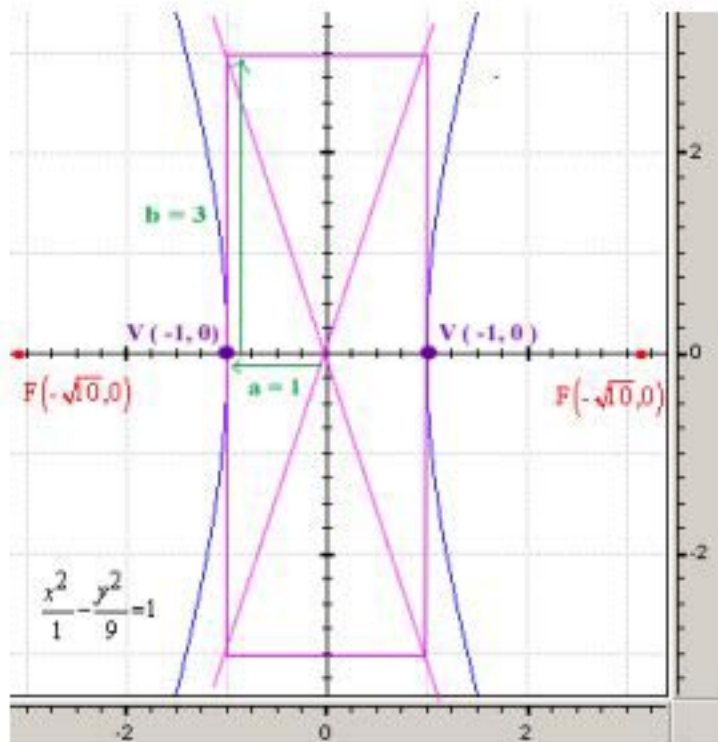
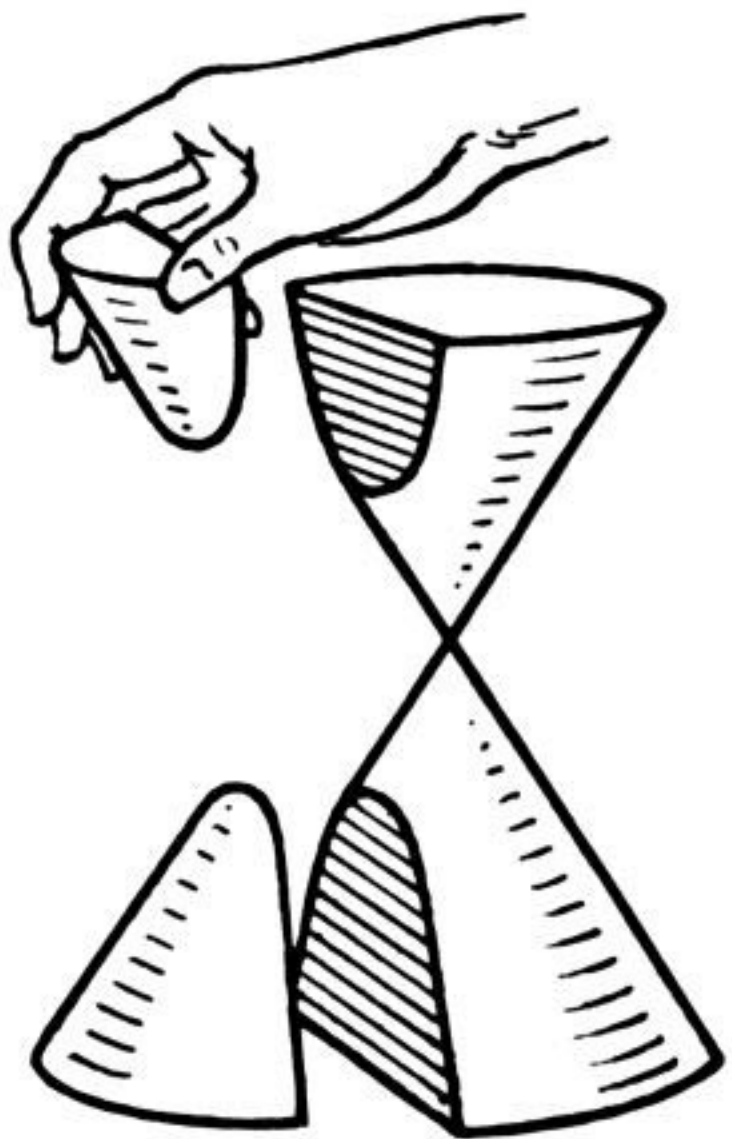

Hyperbola

Biomimicry Design by Nature

Mercedes Bionic Concept Car - Boxfish



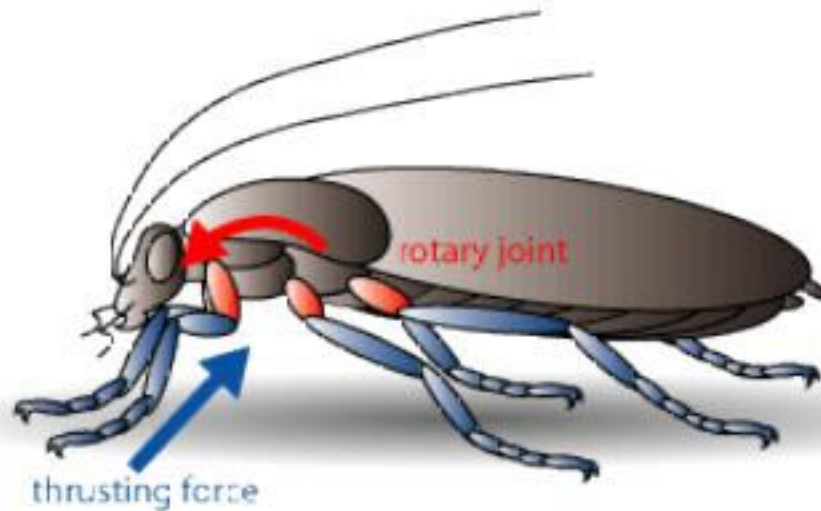
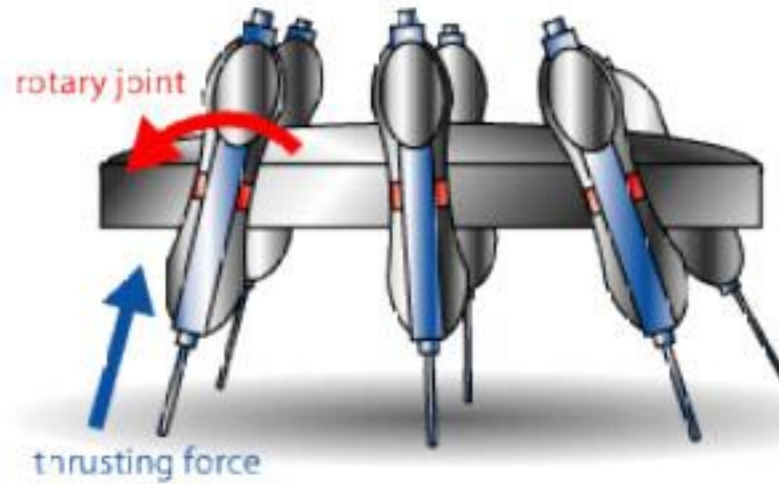

Biomimicry researchers at Stanford, Harvard Universities modelling the **joint and leg structure** of the **cockroach** for the development of a **hexapedal** running robot.

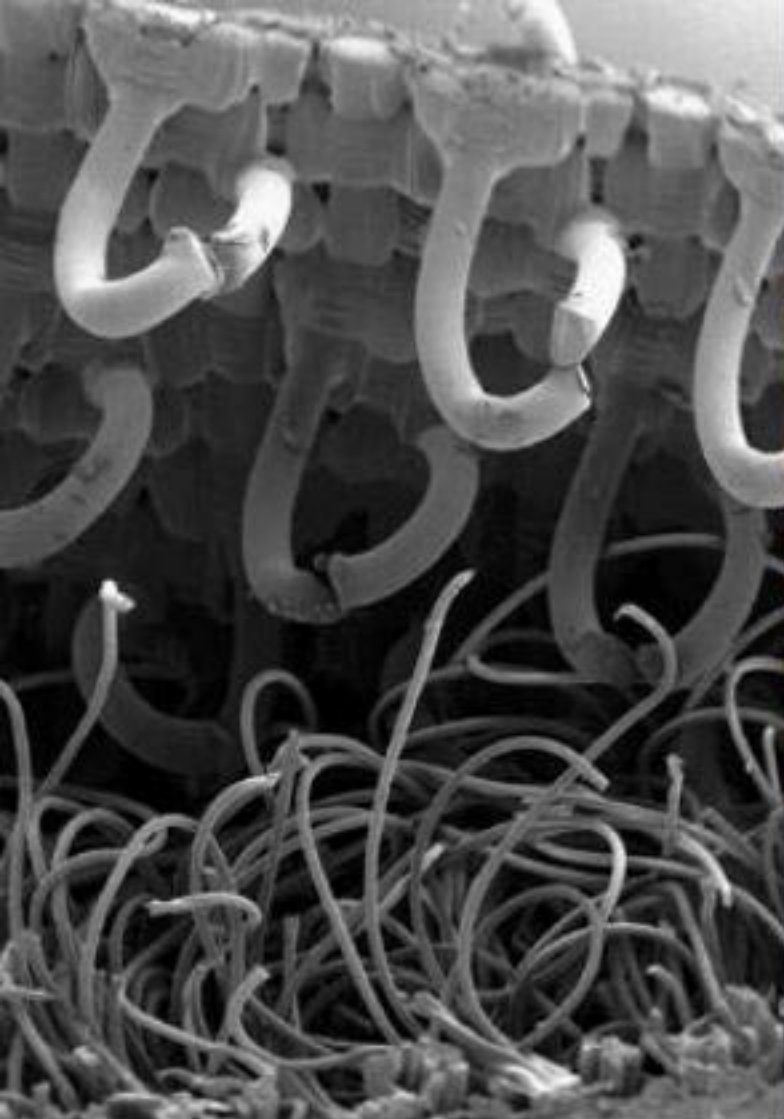

Biomimicry Velcro - Burdock hooks -1948

A photograph of the Milwaukee Art Museum, designed by Santiago Calatrava. The building is a prime example of organic architecture, featuring a white, ribbed structure that resembles a bird in flight or a sailboat. A prominent, tall, white pylon is supported by a network of thin cables. The building's facade is composed of a grid of white ribs that create a series of overlapping, wing-like sections. The museum is set against a clear blue sky with scattered white clouds. In the foreground, there is a well-maintained green lawn and a paved walkway. A few people can be seen walking near the entrance of the building.

Santiago Calatrava, Milwaukee Art Museum

http://www.youtube.com/watch?v=dwR_r8IK4gc

Gestalt (shape) principles of perception 1890

"things are better described as "more than the sum of their parts."

Symmetry

Similarity

Proximity

Closure

Symmetry

Symmetry is property of visual equivalence
among elements of form

There are three types of symmetry

Reflection Rotation Translation

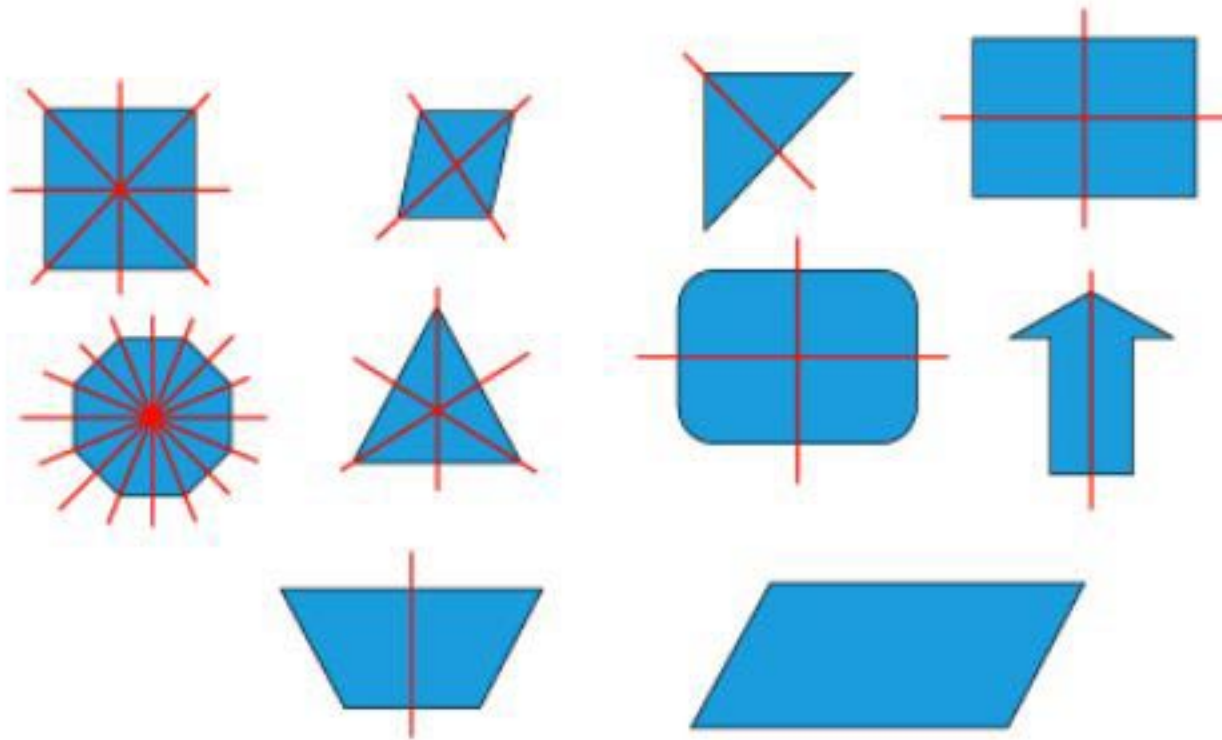

Symmetry

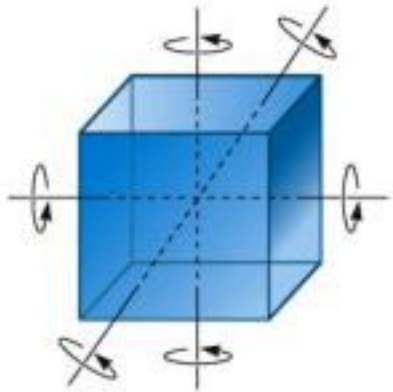

Three 4-fold axes



Four 3-fold axes

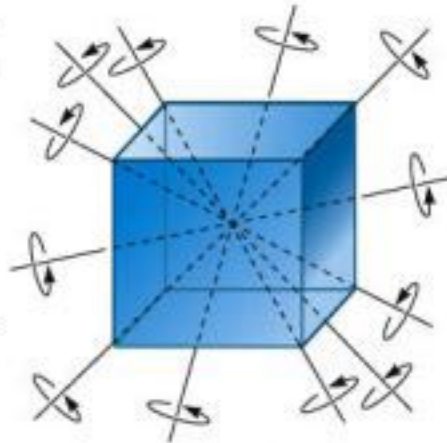

Six 2-fold axes

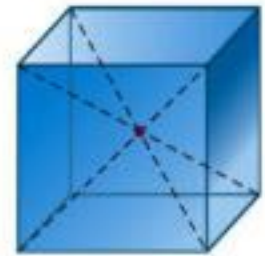

Center of inversion

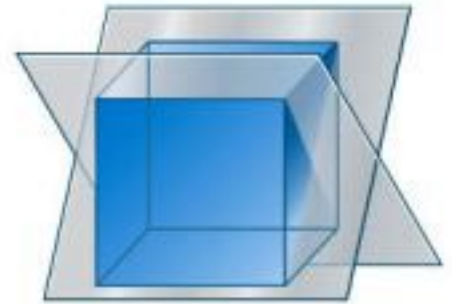
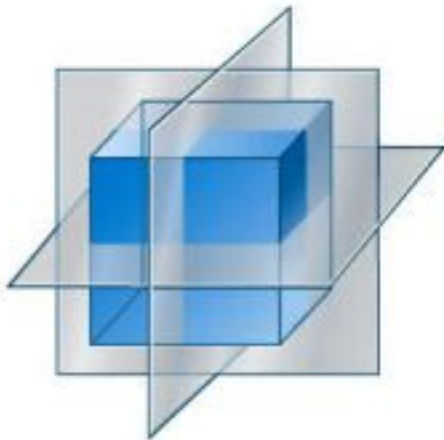

Similarity

Elements that are similar are perceived to be more related than elements that are dissimilar

Elements that are similar are perceived as being part of a group

Lack of symmetry results in the perception of multiple, discrete groups

Use similarity to indicate relatedness amongst elements in design



Proximity

Elements that are closer together are perceived as being more related than elements that are further apart

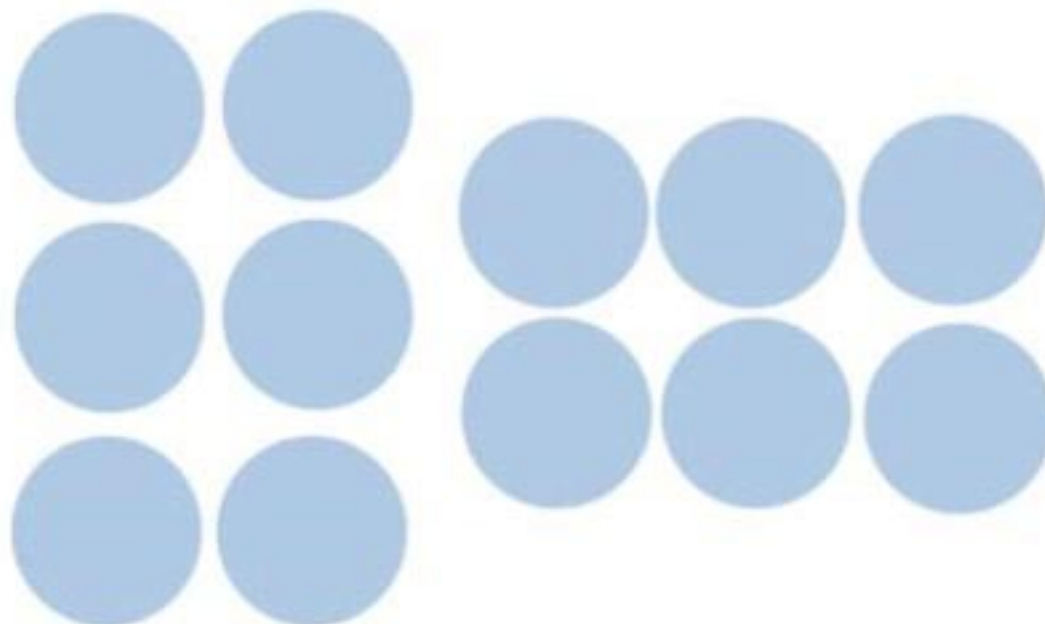



Daniel Libeskind

Performing Arts Centre
Grand Canal Square

Closure

Elements grouped together are seen as a whole. We tend to complete contour lines

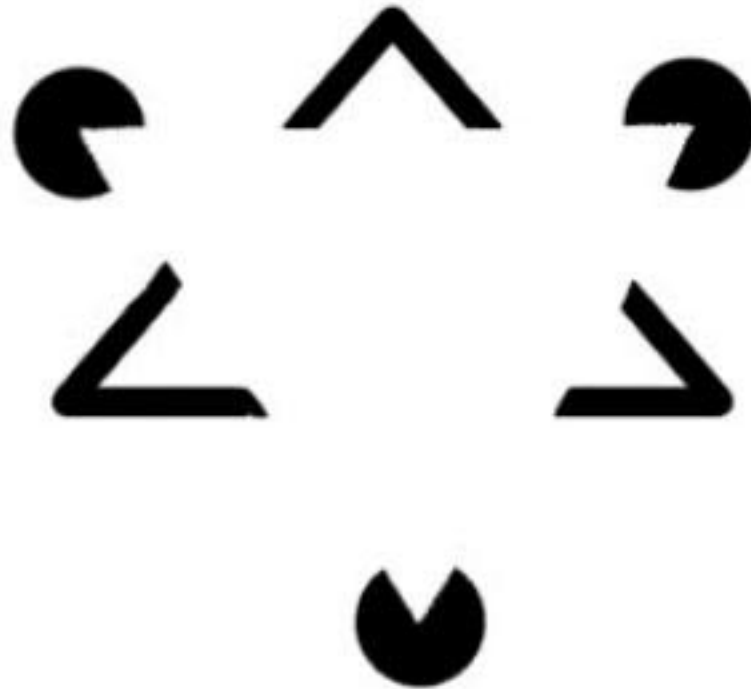

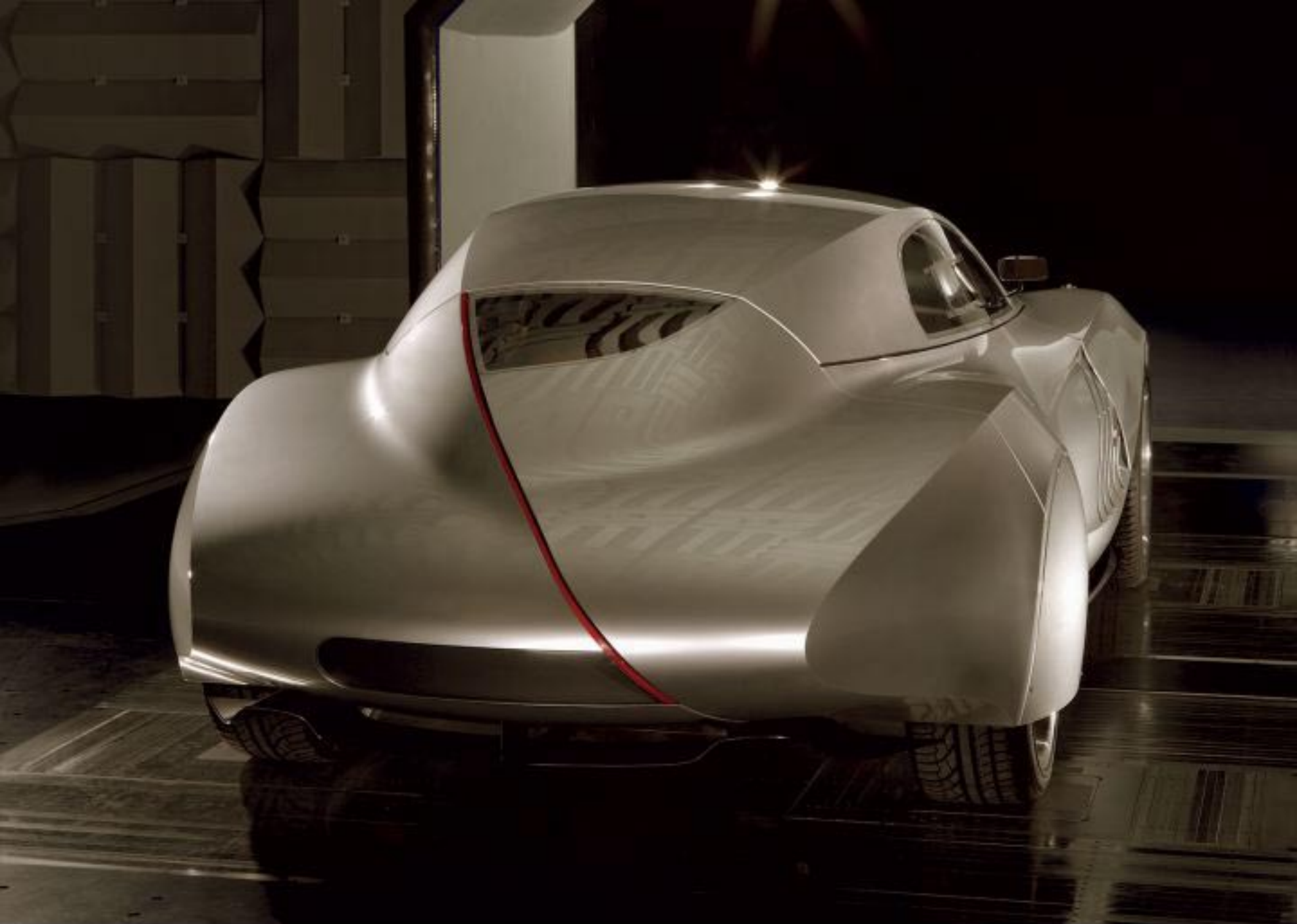





Golden Section – Charles Eames 1946

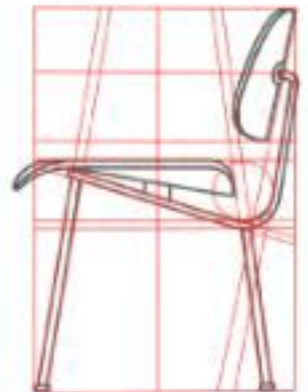
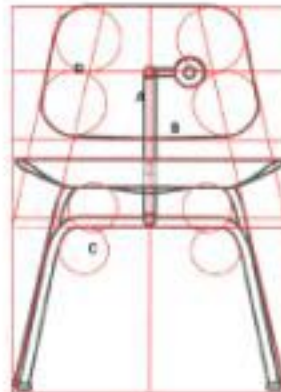
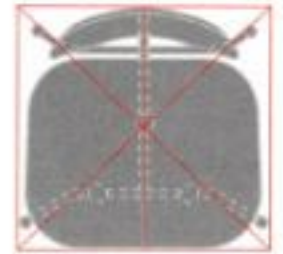
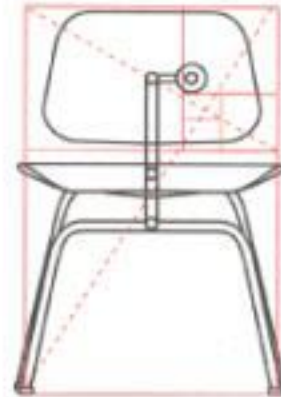
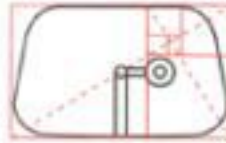

Barcelona Chair Mies van der Rohe 1929

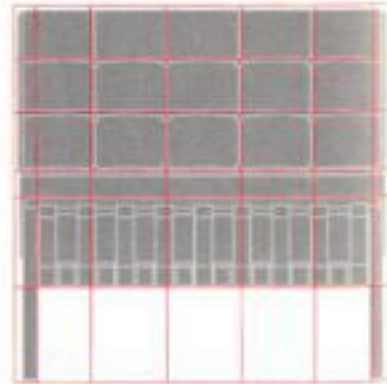
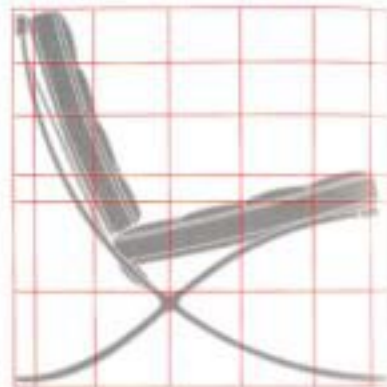

Chair Proportions (right)

The chair side view (top right) as well as front view (bottom right) fit perfectly into a square. The divisions of the back cushion approximate small root 2 rectangles.

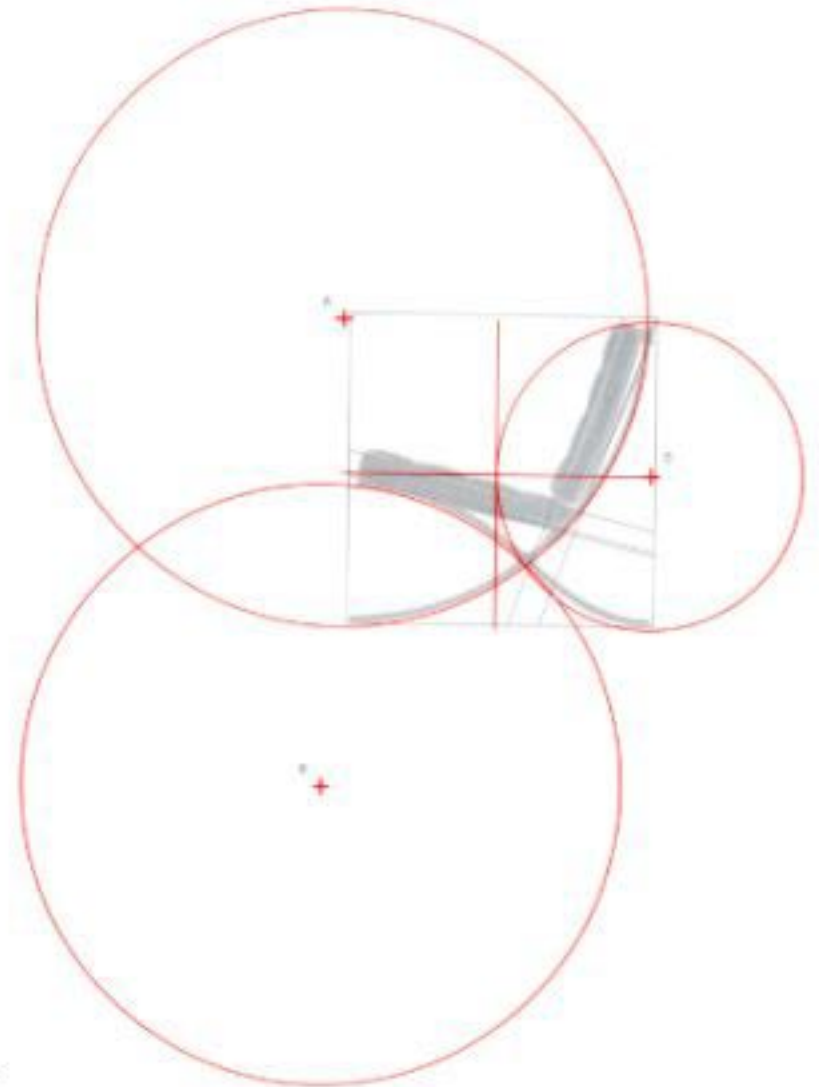

Braun Radio 1959



Braun Coffee Maker 1975



Dieter Rams - 10 Principles of 'good design'

is innovative.

makes a product useful.

is aesthetic.

helps us to understand a product.

is unobtrusive.

is honest.

is durable.

is consequent to the last detail.

is concerned with the environment.

is as little design as possible.



iPod - Generation 1



Sony flatscreen TV



Daniel Libeskind - Spirit House Chair

Aldo Rossi Kettle 1983

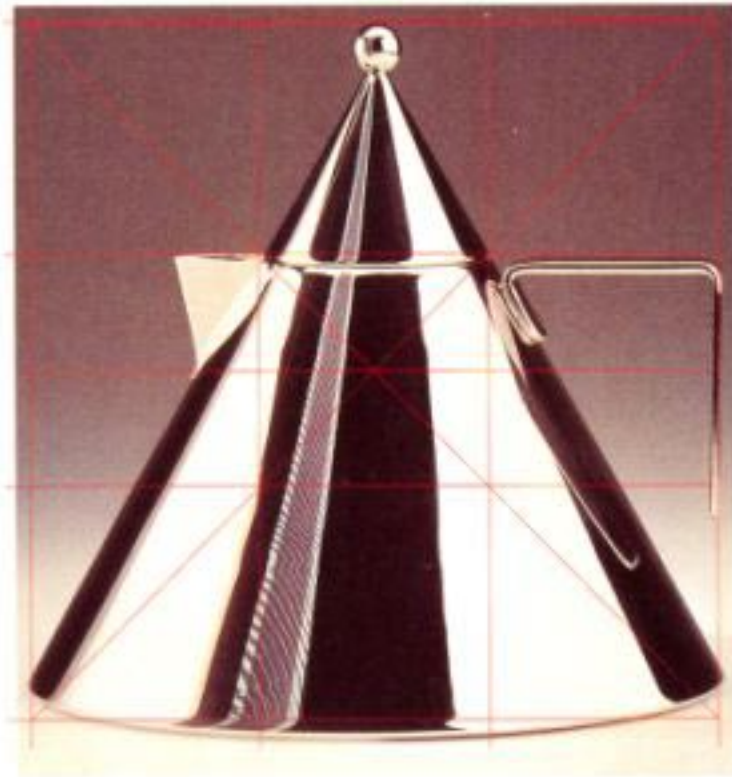
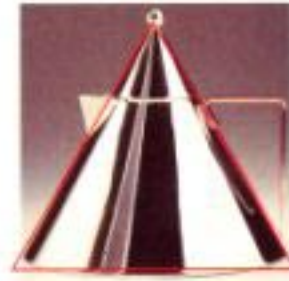

Golden Section - VW Beetle 1997

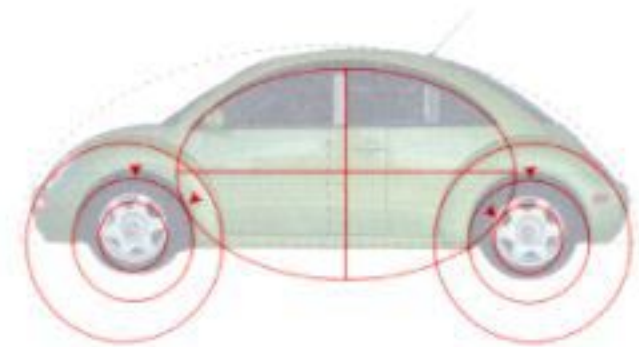
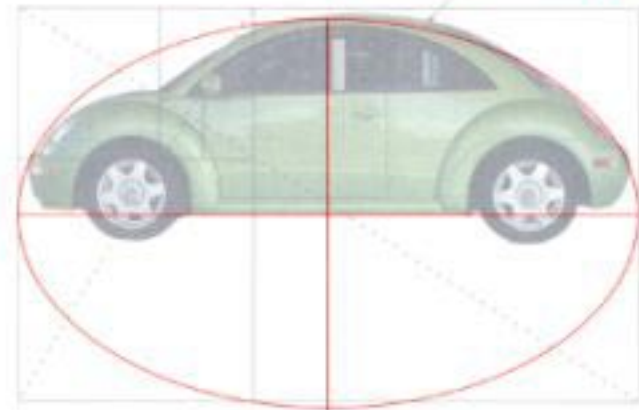
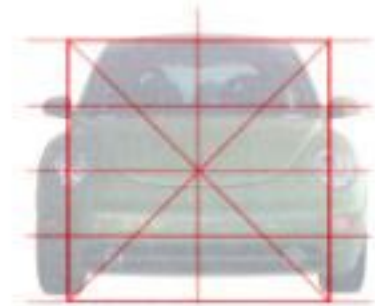
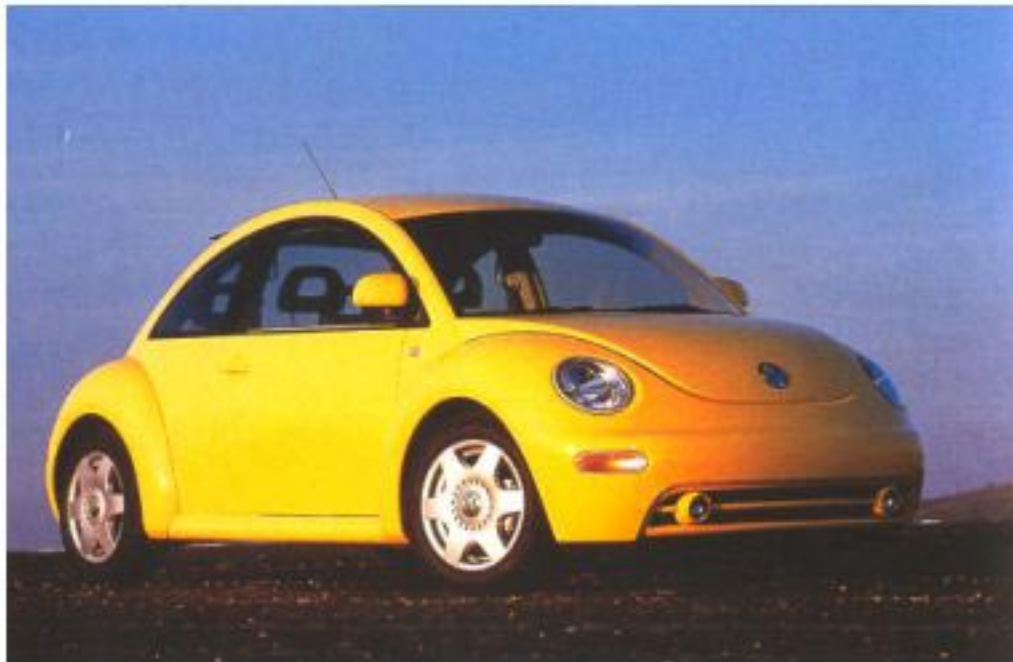





Tangent Intersection

90 deg
Golden rectangle

Golden rectangle

90 deg

Visual vocabulary

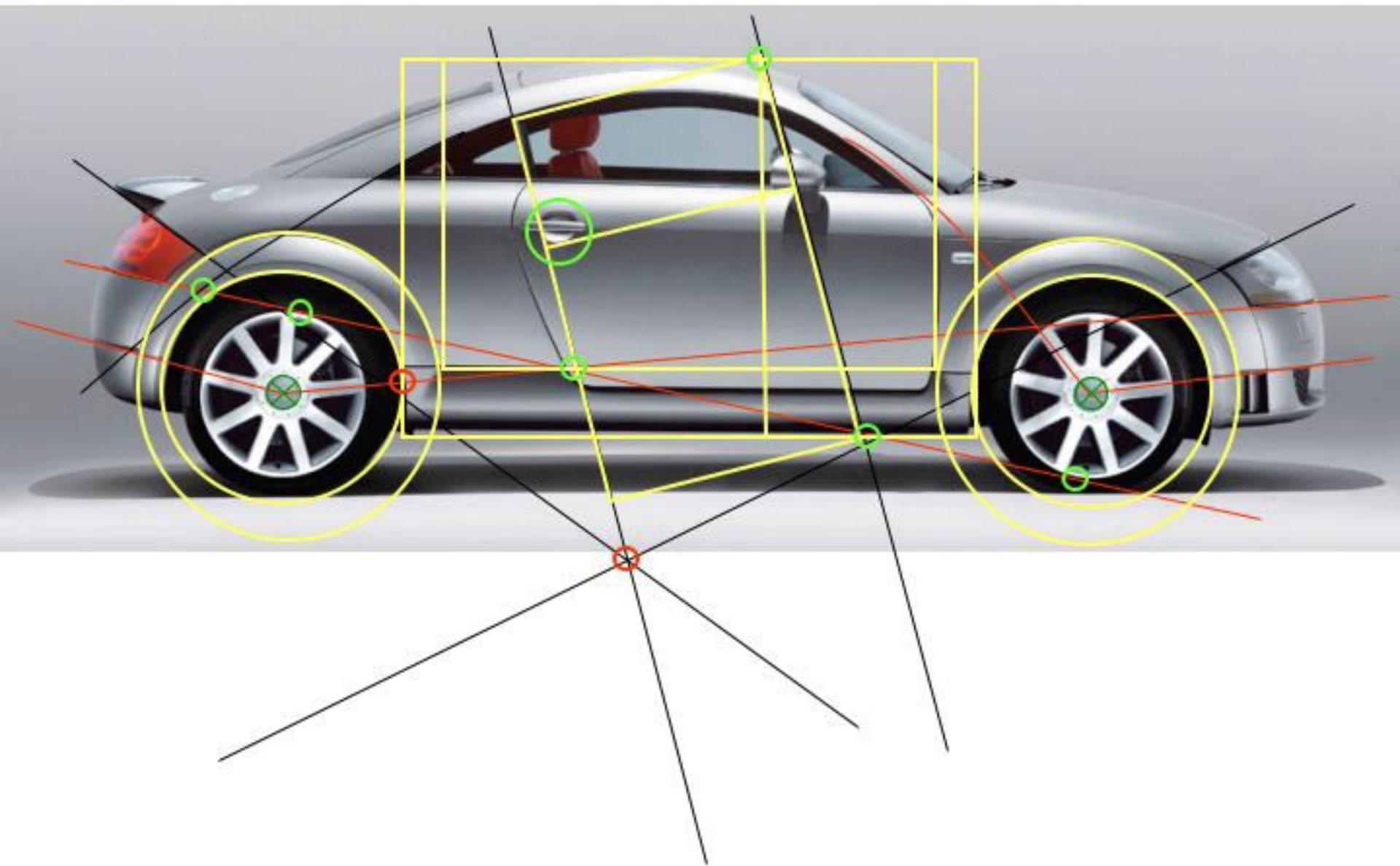

Visual vocabulary

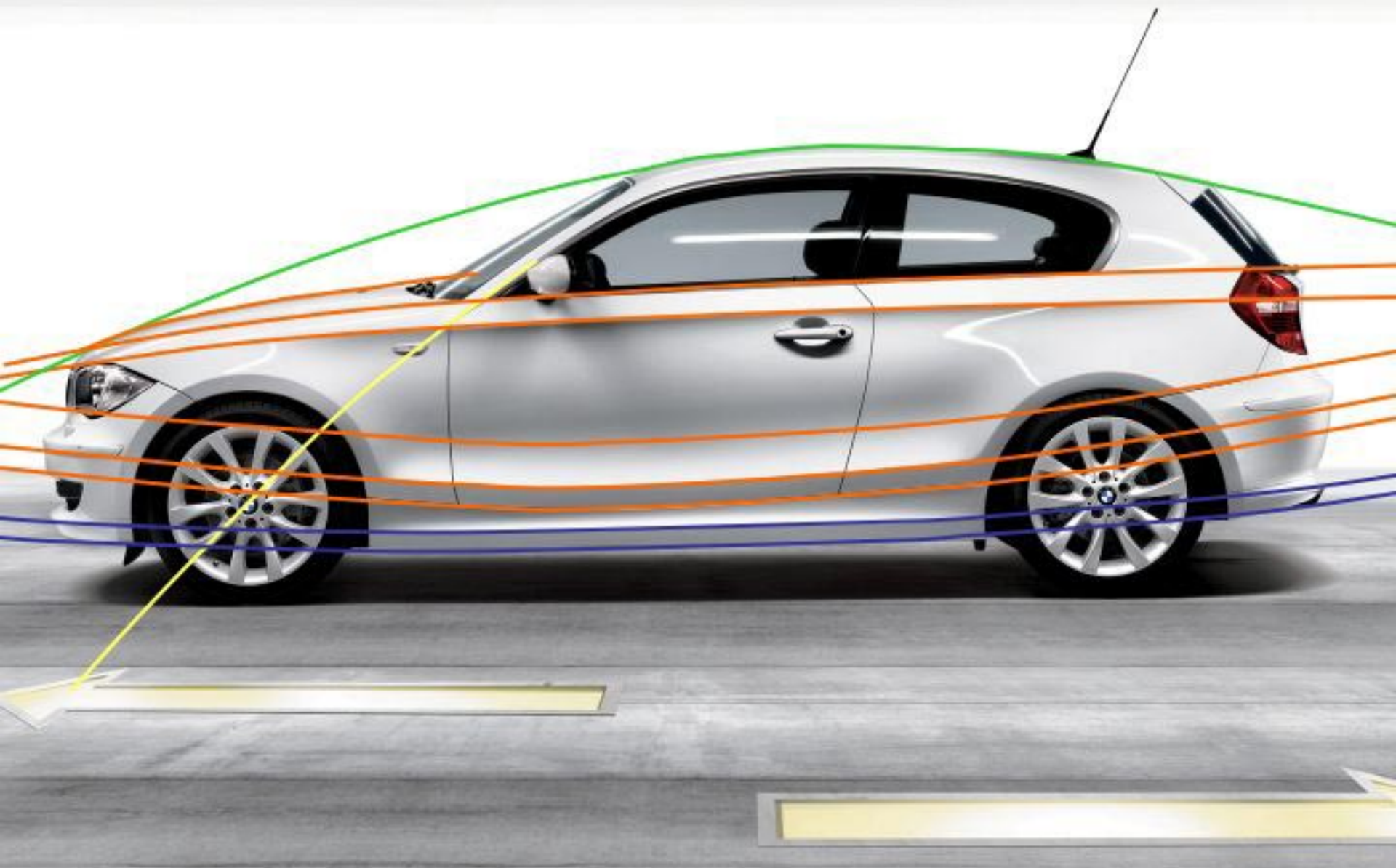

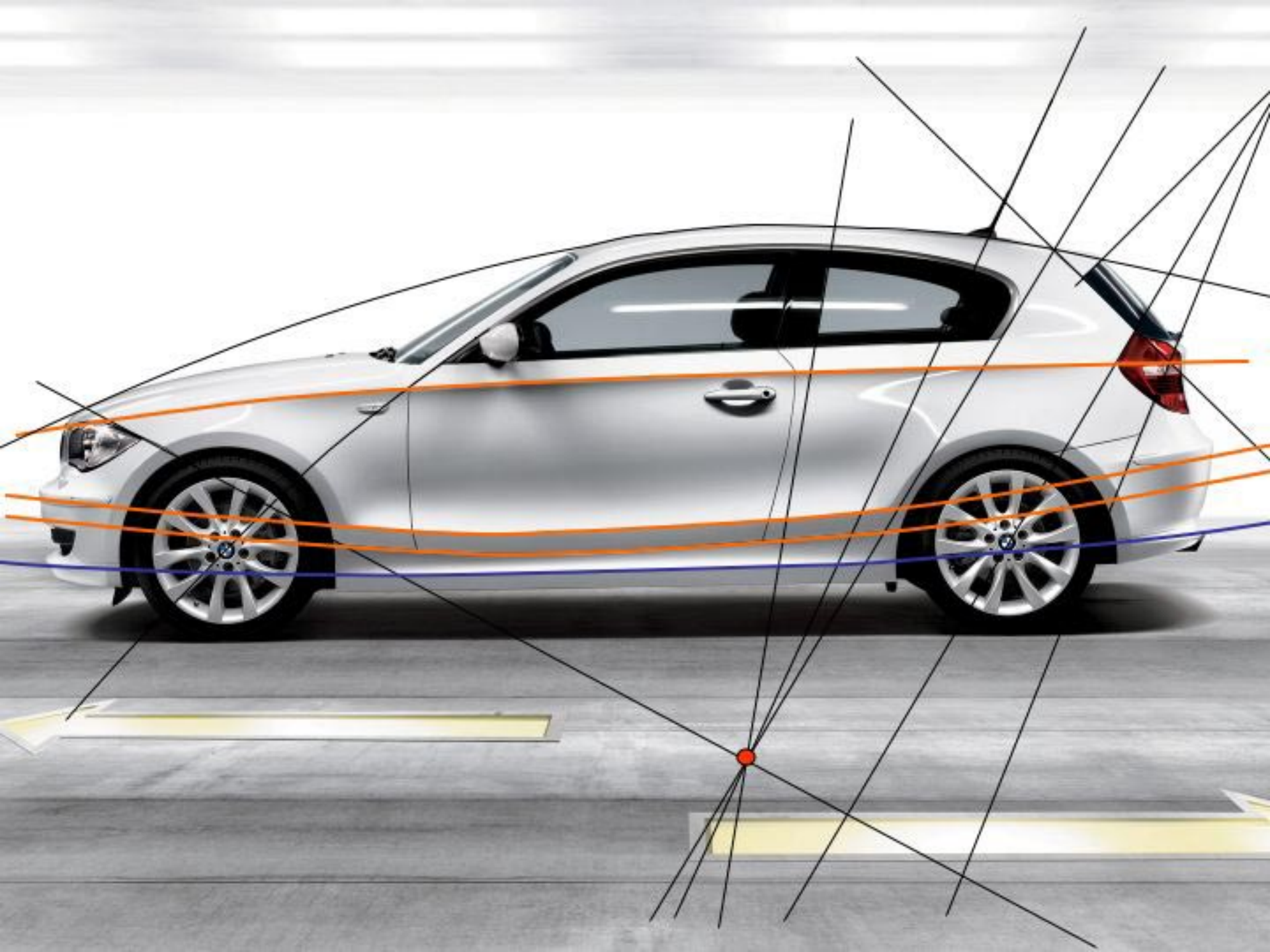

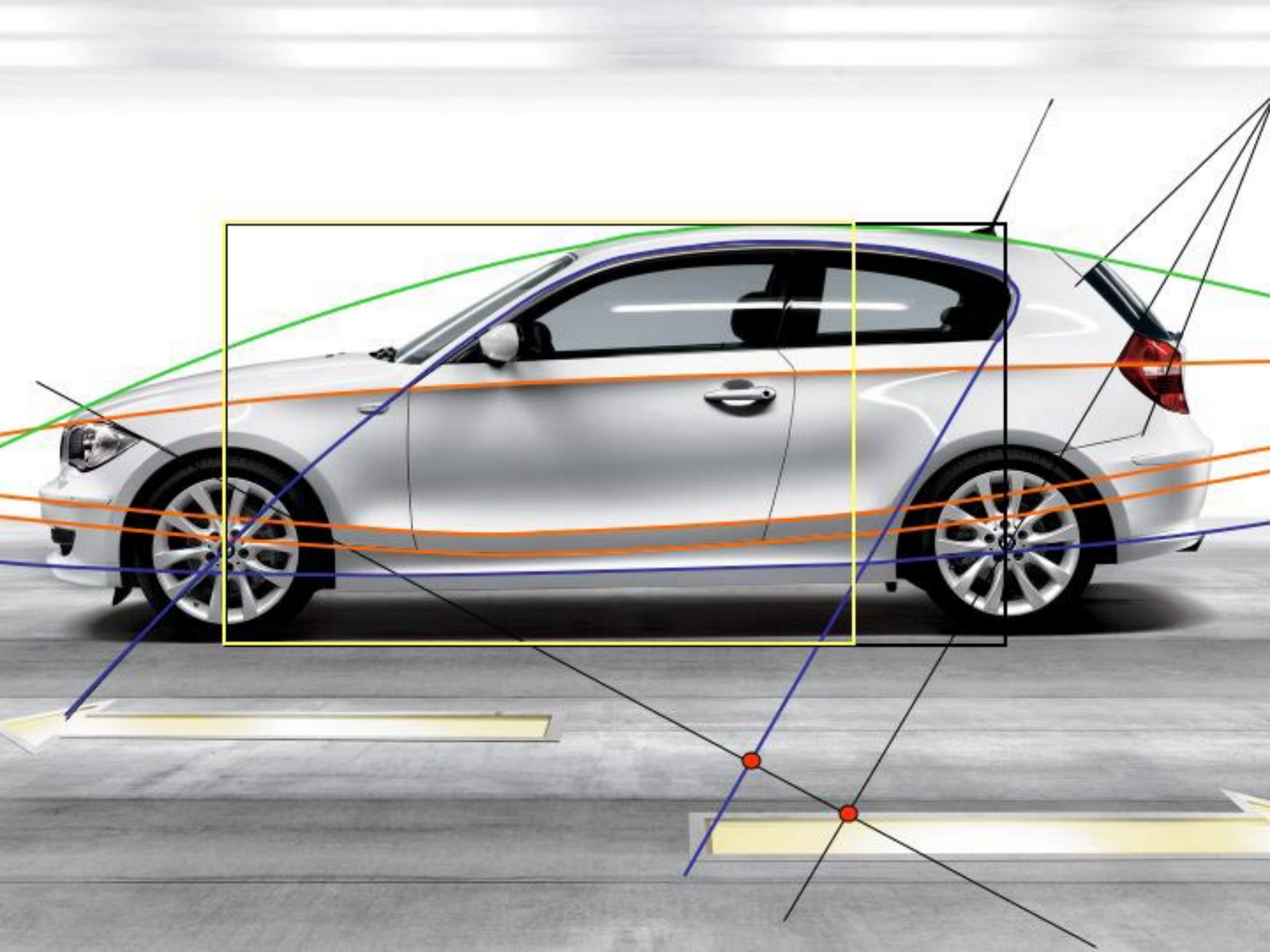

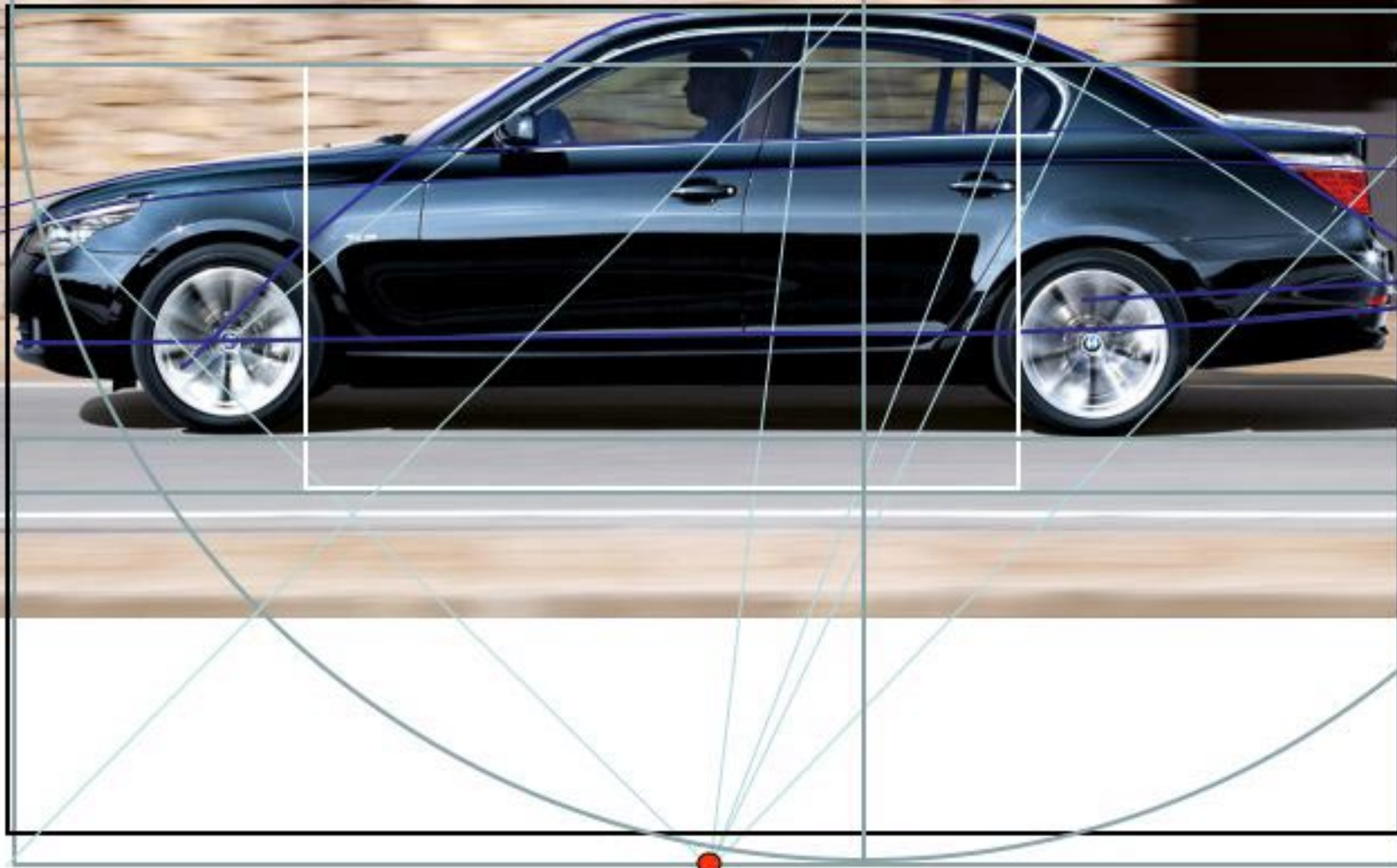

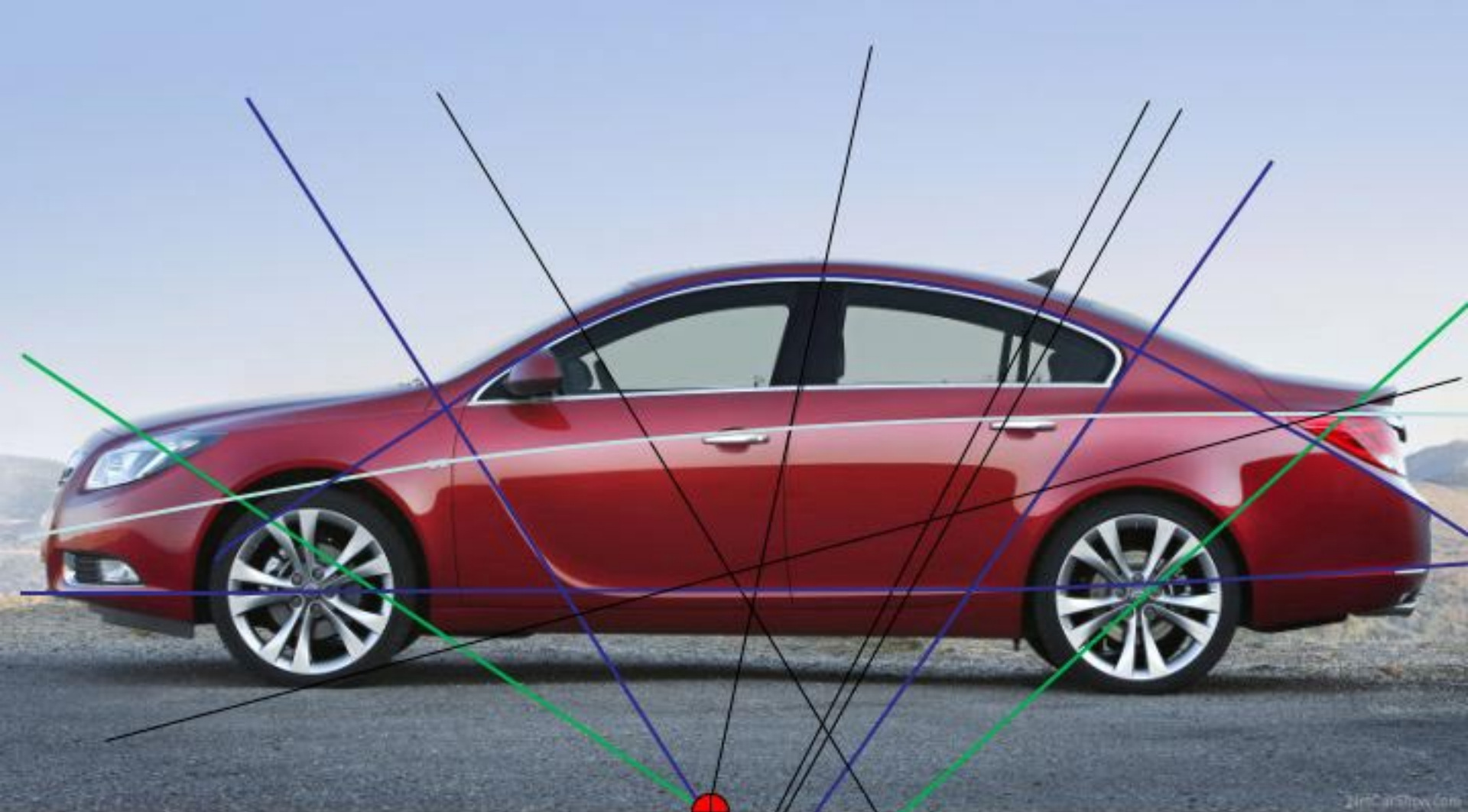

21stCarShow.com

Formal Literacy Project

The project is devised to explore the relationships between a range of two-dimensional geometric objects. Out of this exploration, identify visually interesting patterns and three-dimensional structures. Construct a nonfunctional object which illustrates your most remarkable and attractive findings.

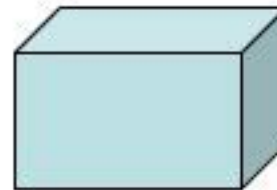
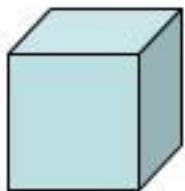
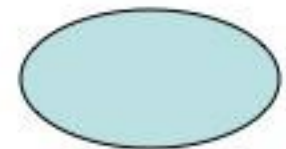
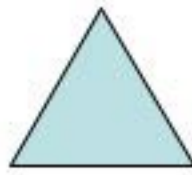
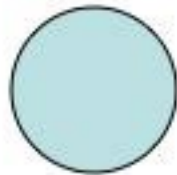

Aims

Stage 1

To study simple proportioning systems and apply them in three-dimensional structures

To explore three-dimensional forms resulting from a study of the relationship between geometric planes and solids

To see the form of an object as an expression of its components, its composition and its proportions

Stage 2

To apply this method in the design of a sample functional product

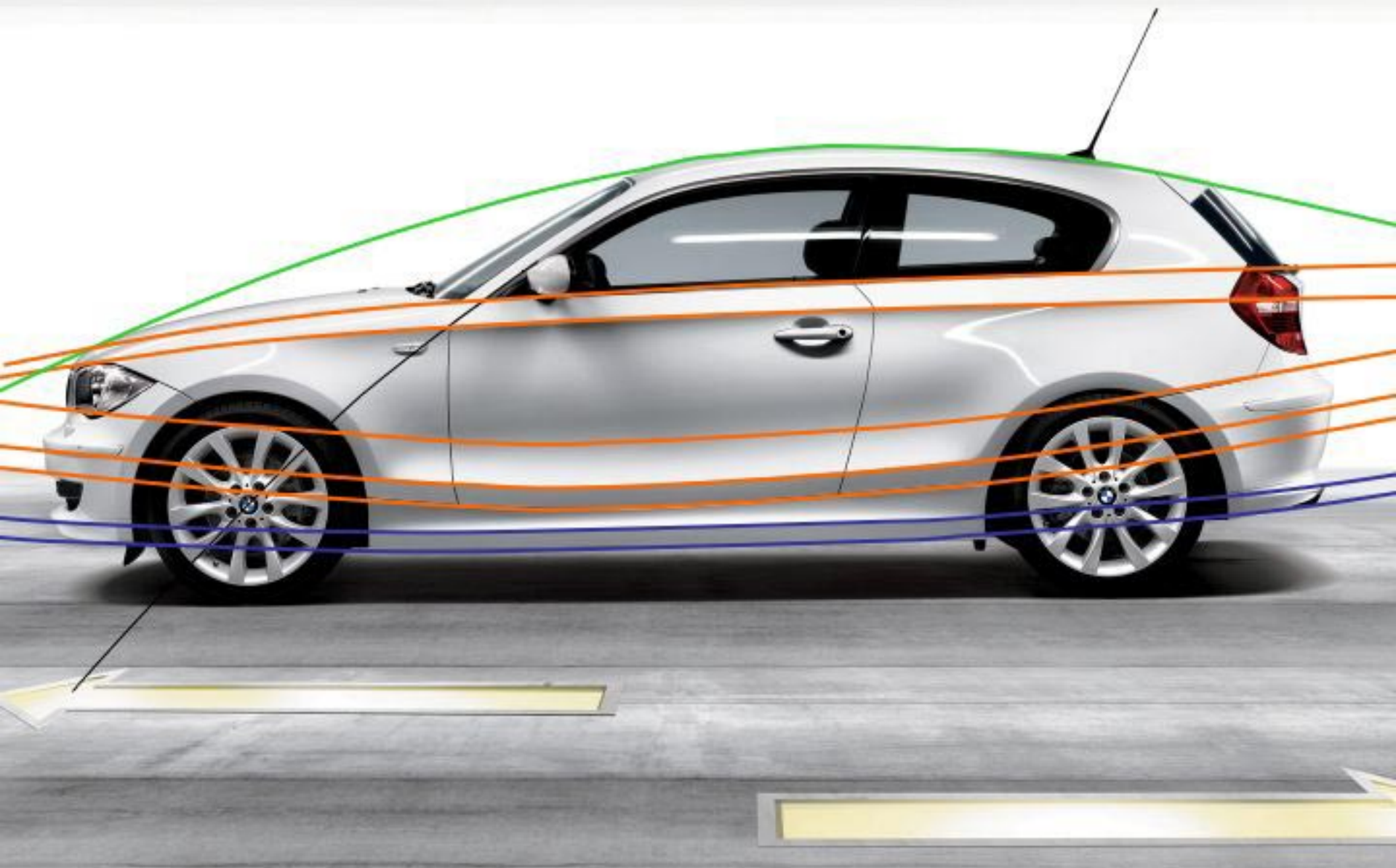

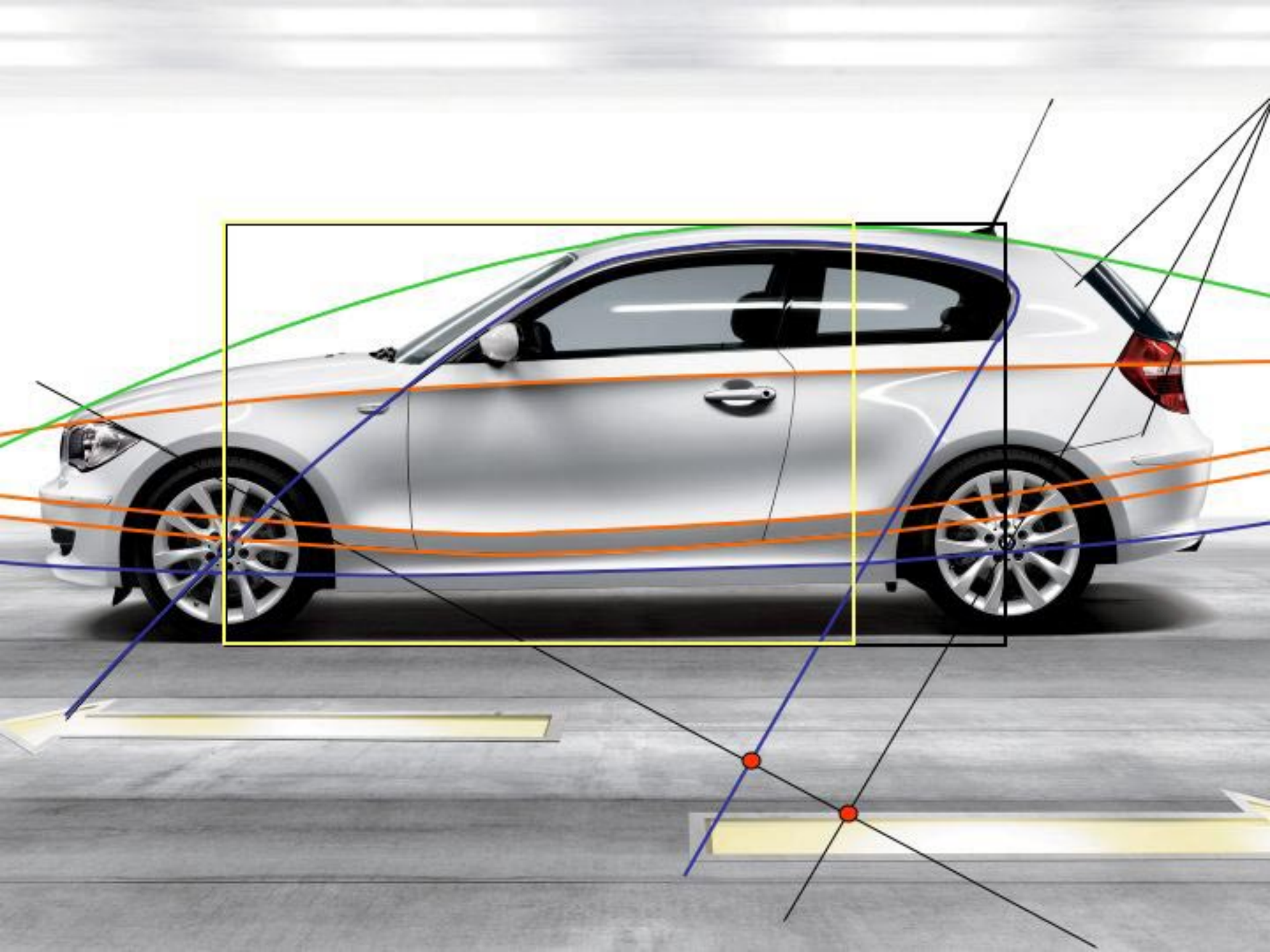

Structure

Generate 3-D geometric forms

2-D shape

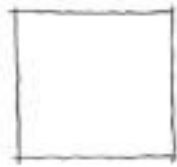

Square

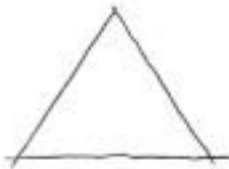

Triangle

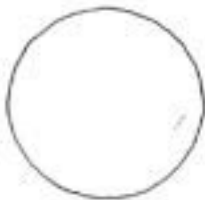

Circle

Extrude

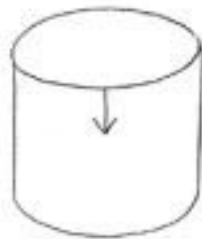
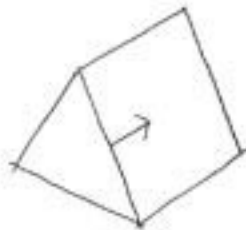
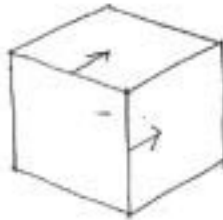

Rotate (centre axis)

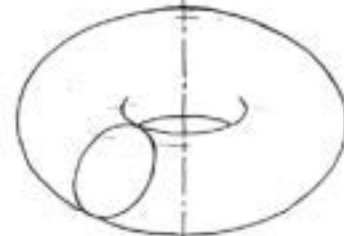
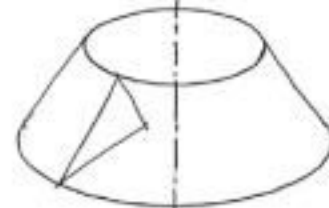
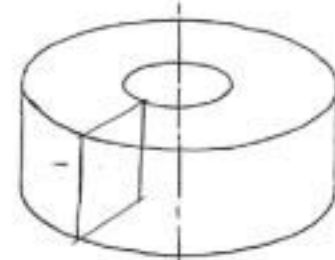
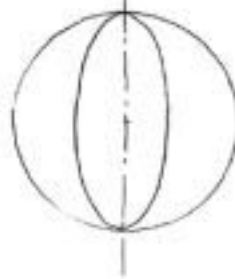
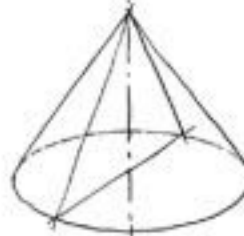
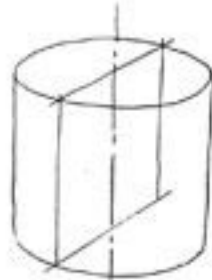

Solid 100mm Cube

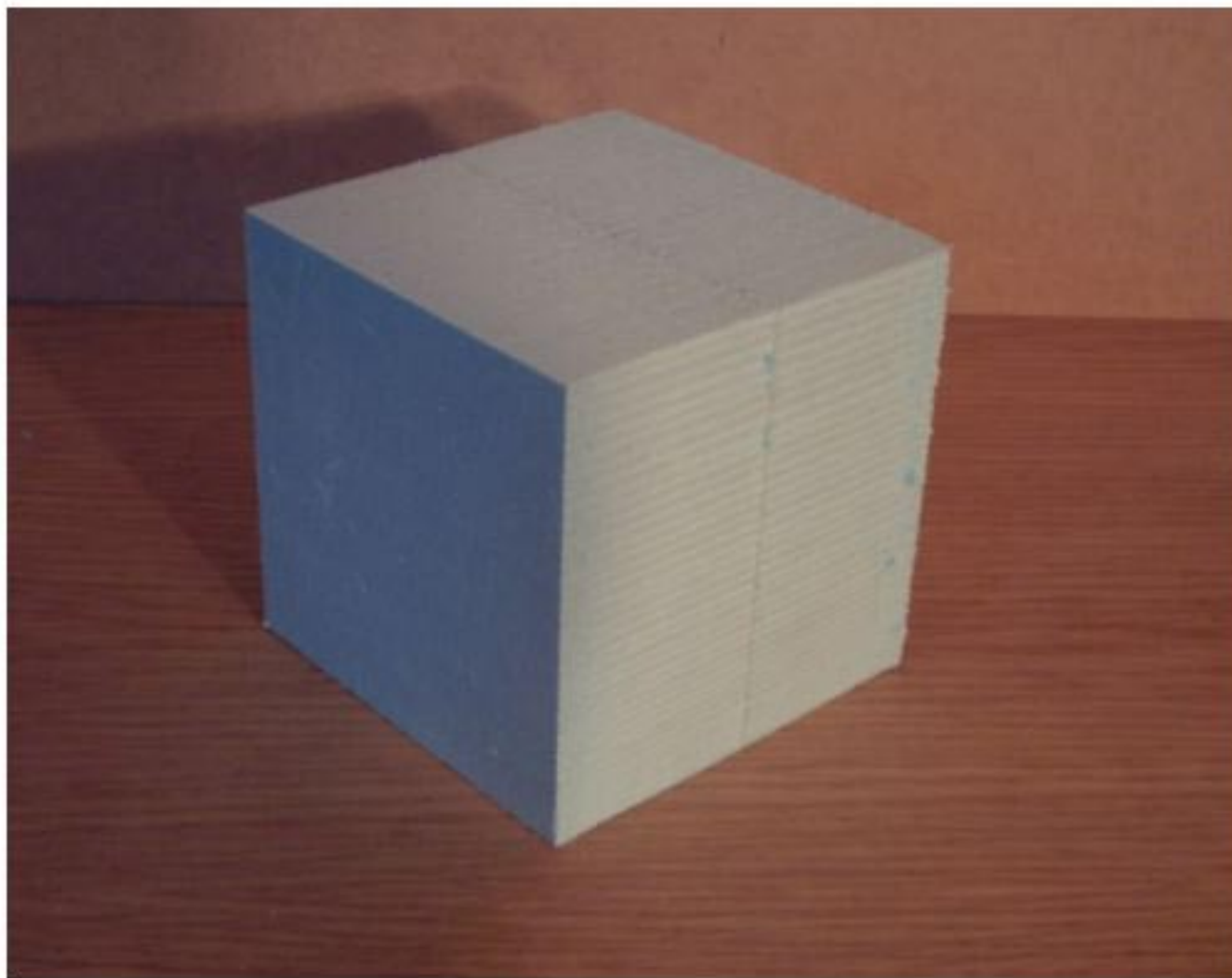

Solid 100mm Cube - No 2

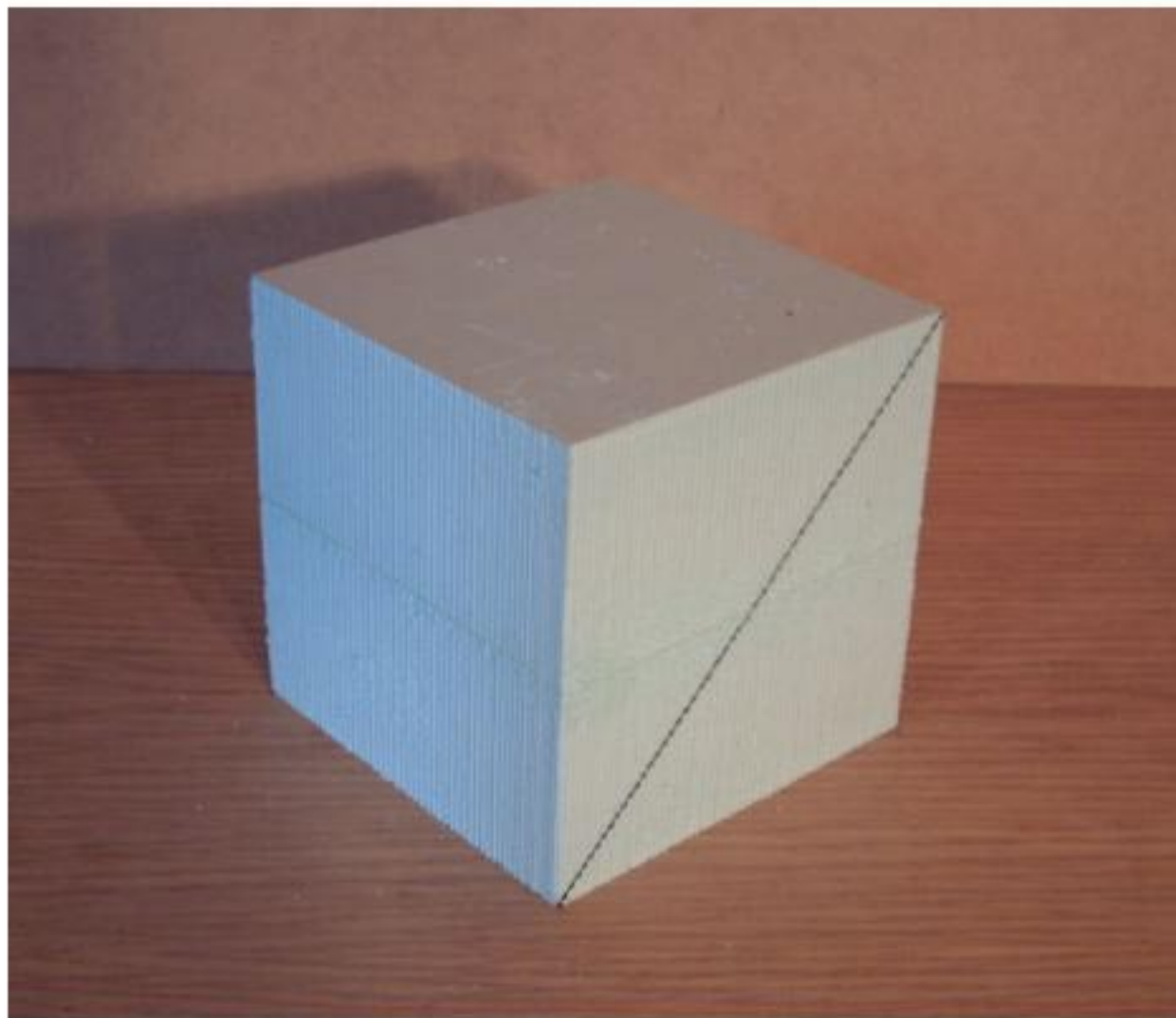

Solid 100mm Cube - No 3

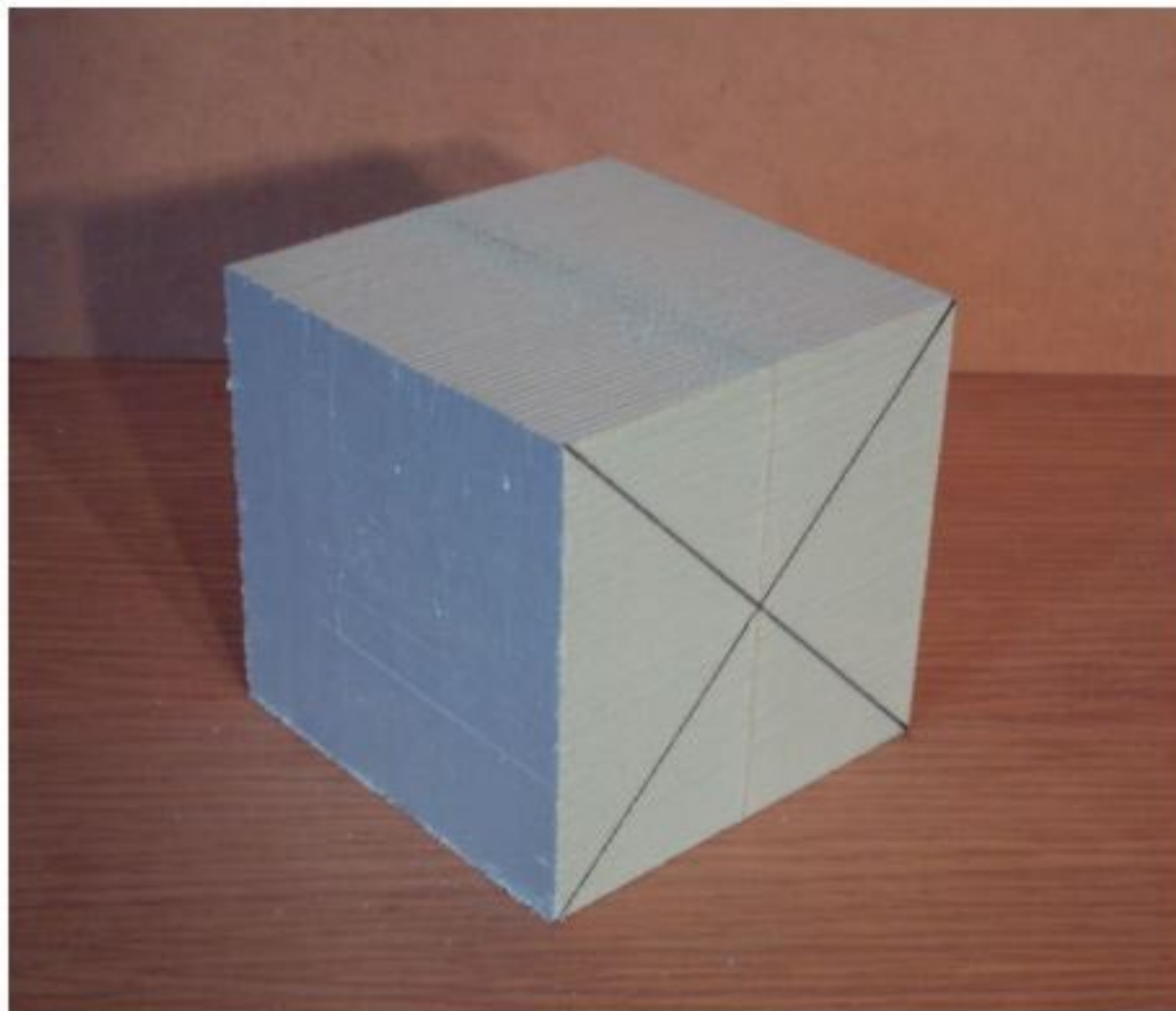

Solid 100mm Cube - No 4

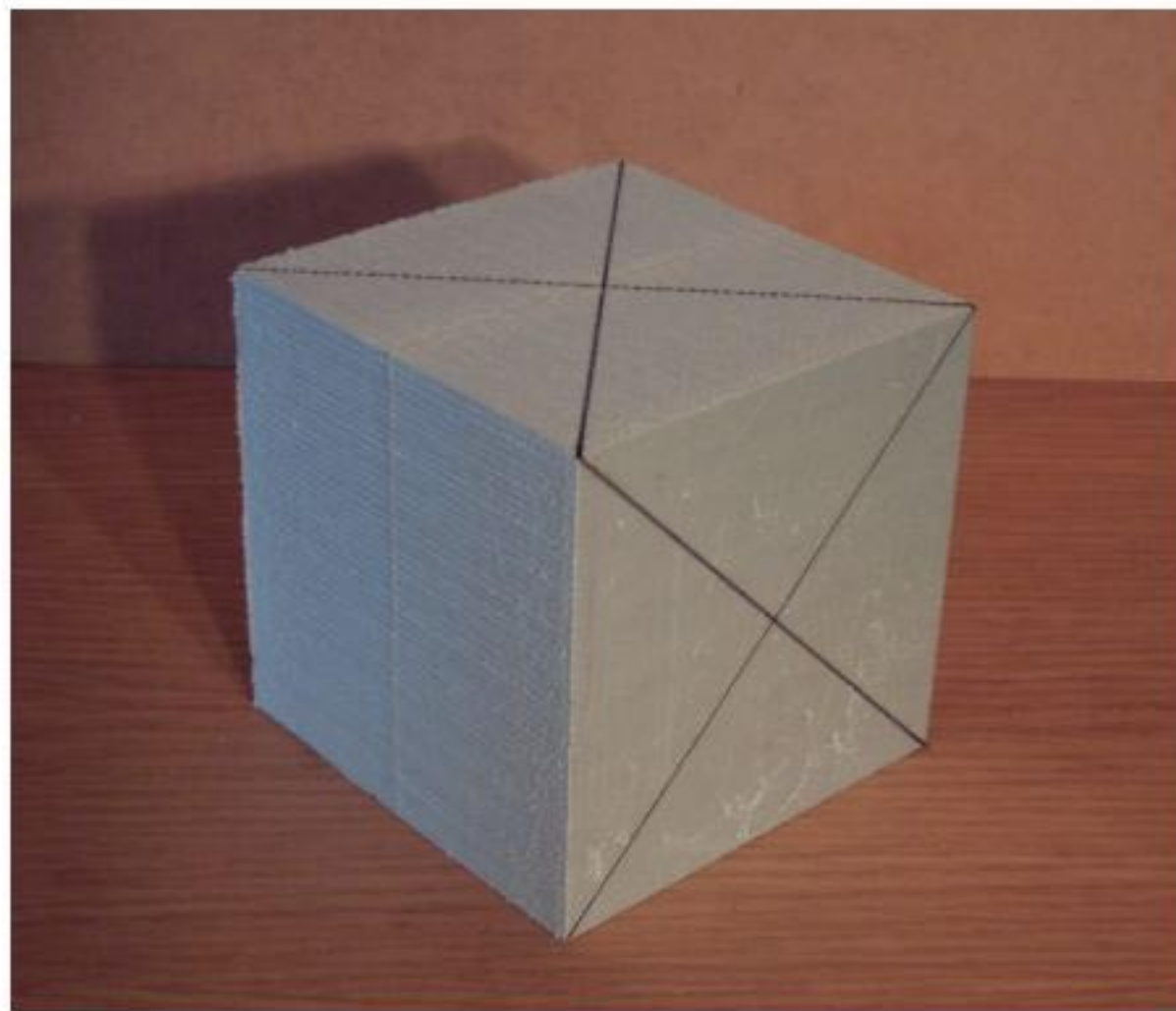

Solid 100mm Cube - No 5

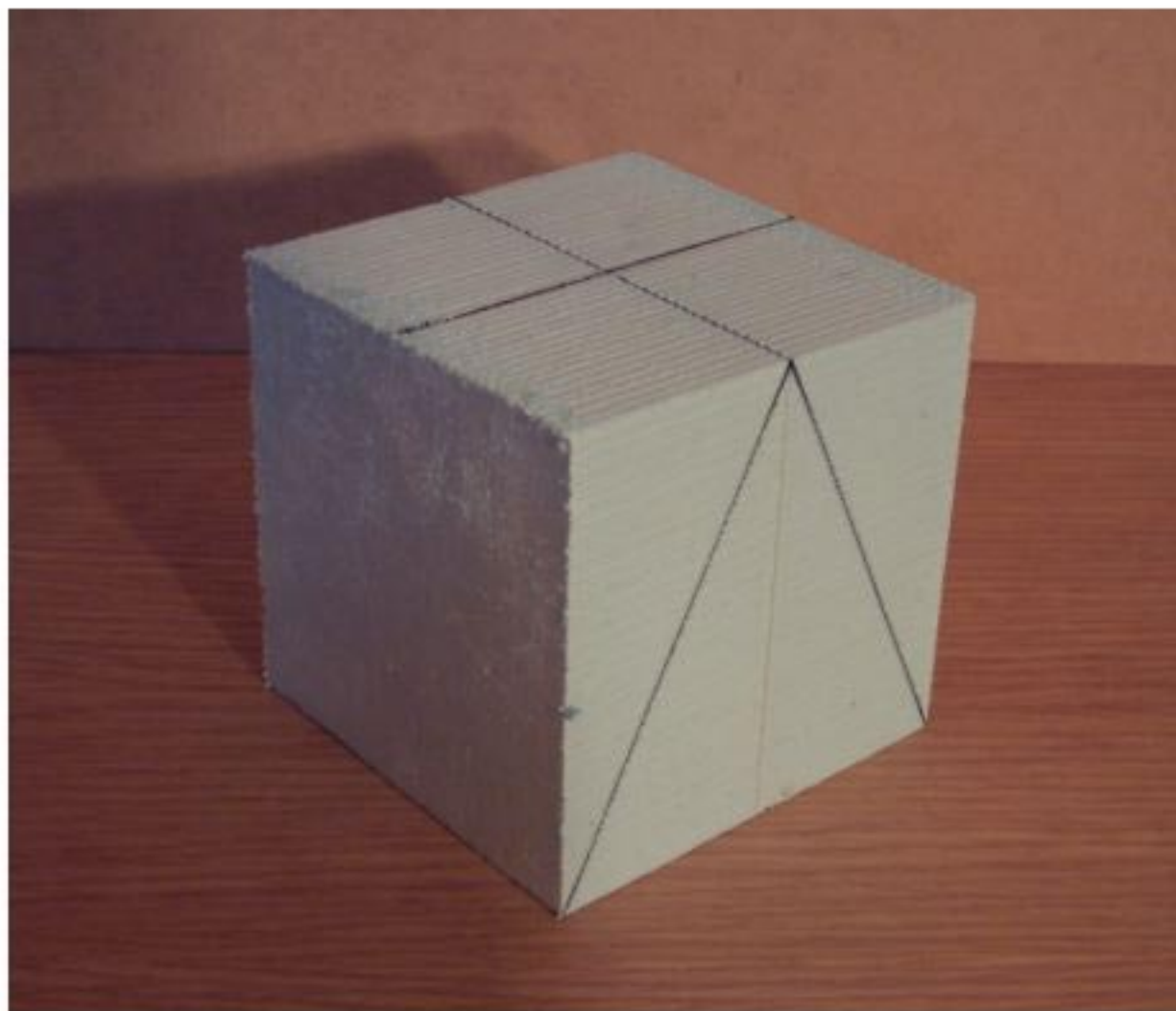

Frank Gehry's Guggenheim Bilbao

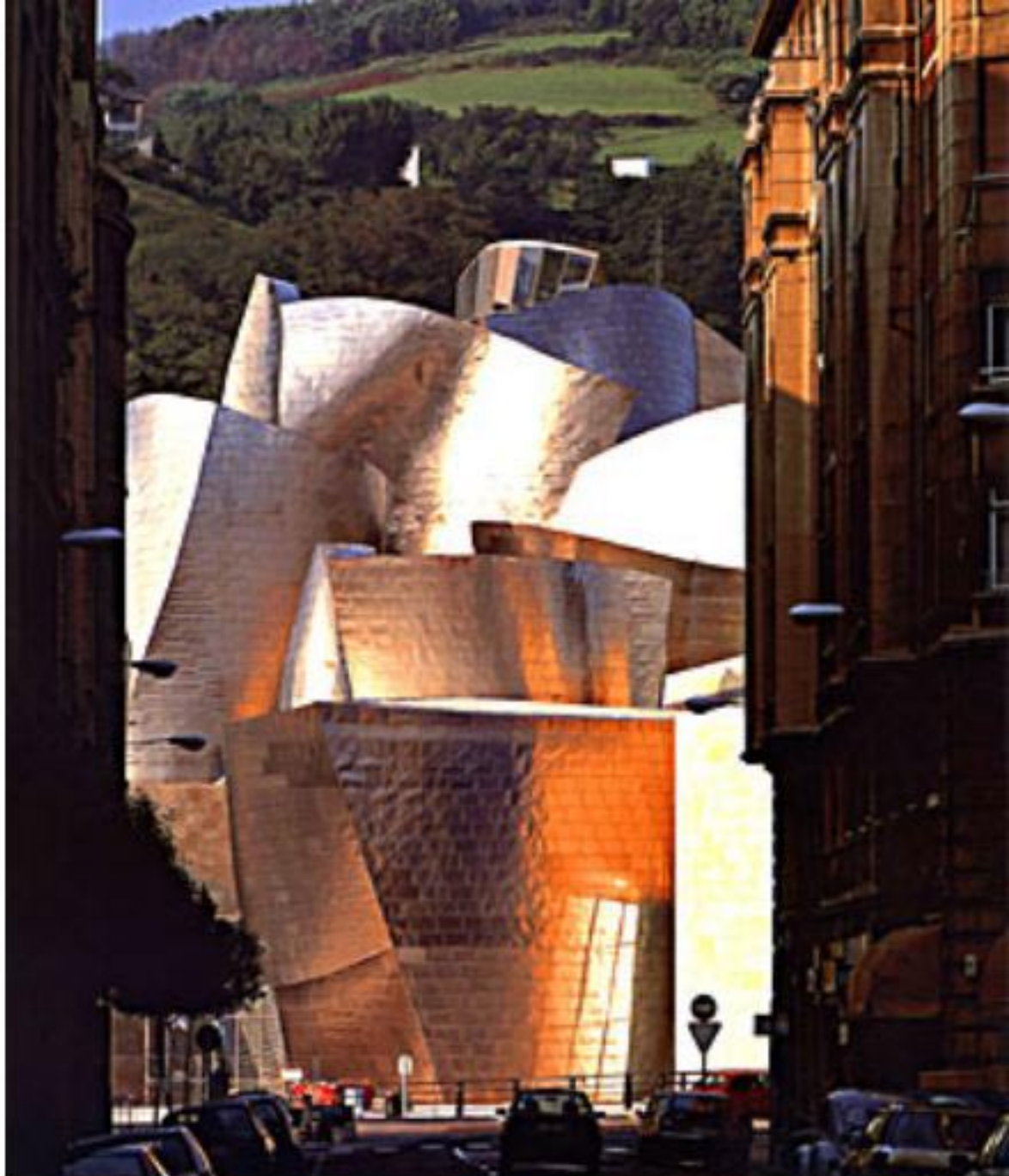

Solid 100mm Cube - No 6

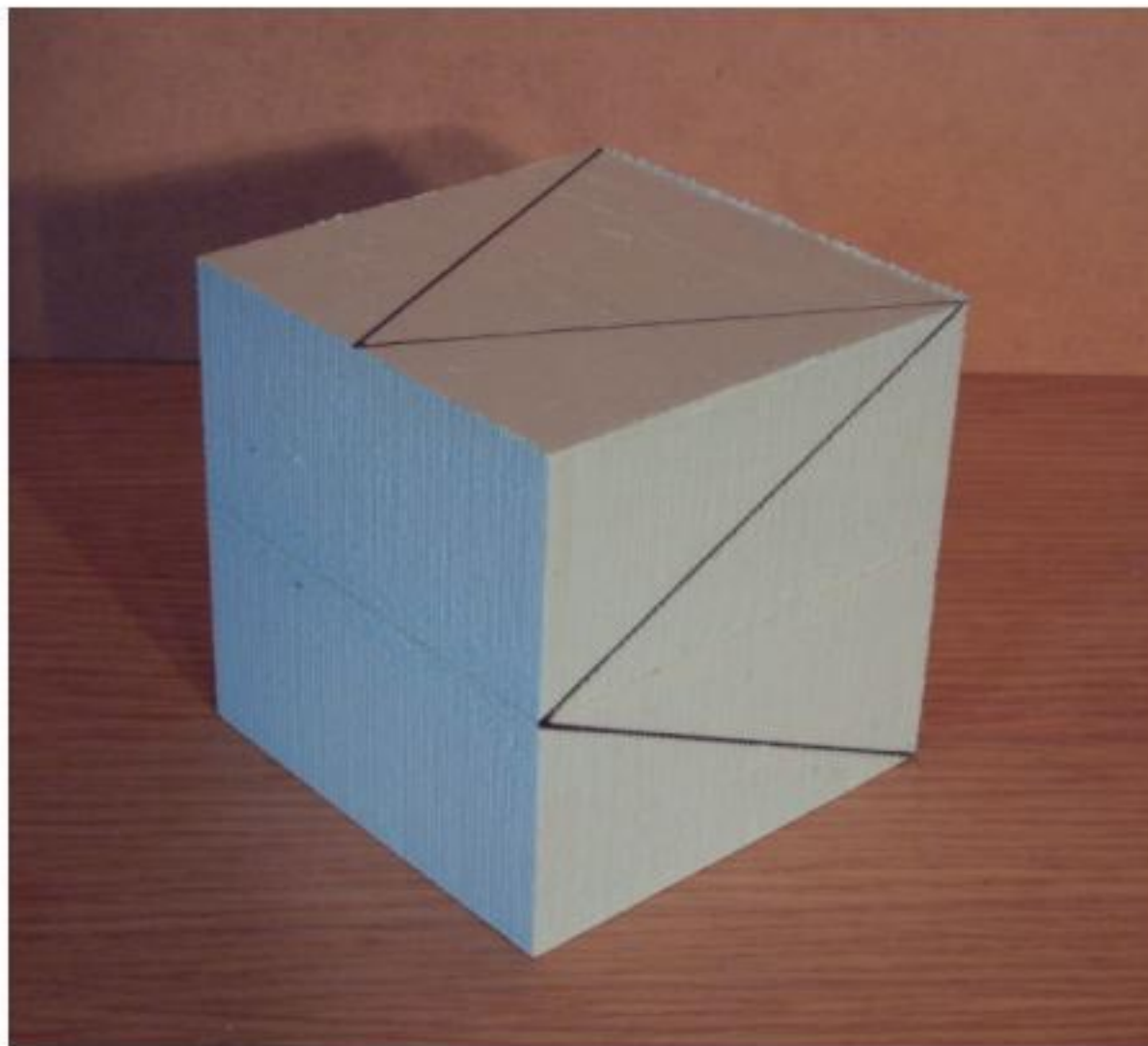

Solid 100mm Cube - No 7

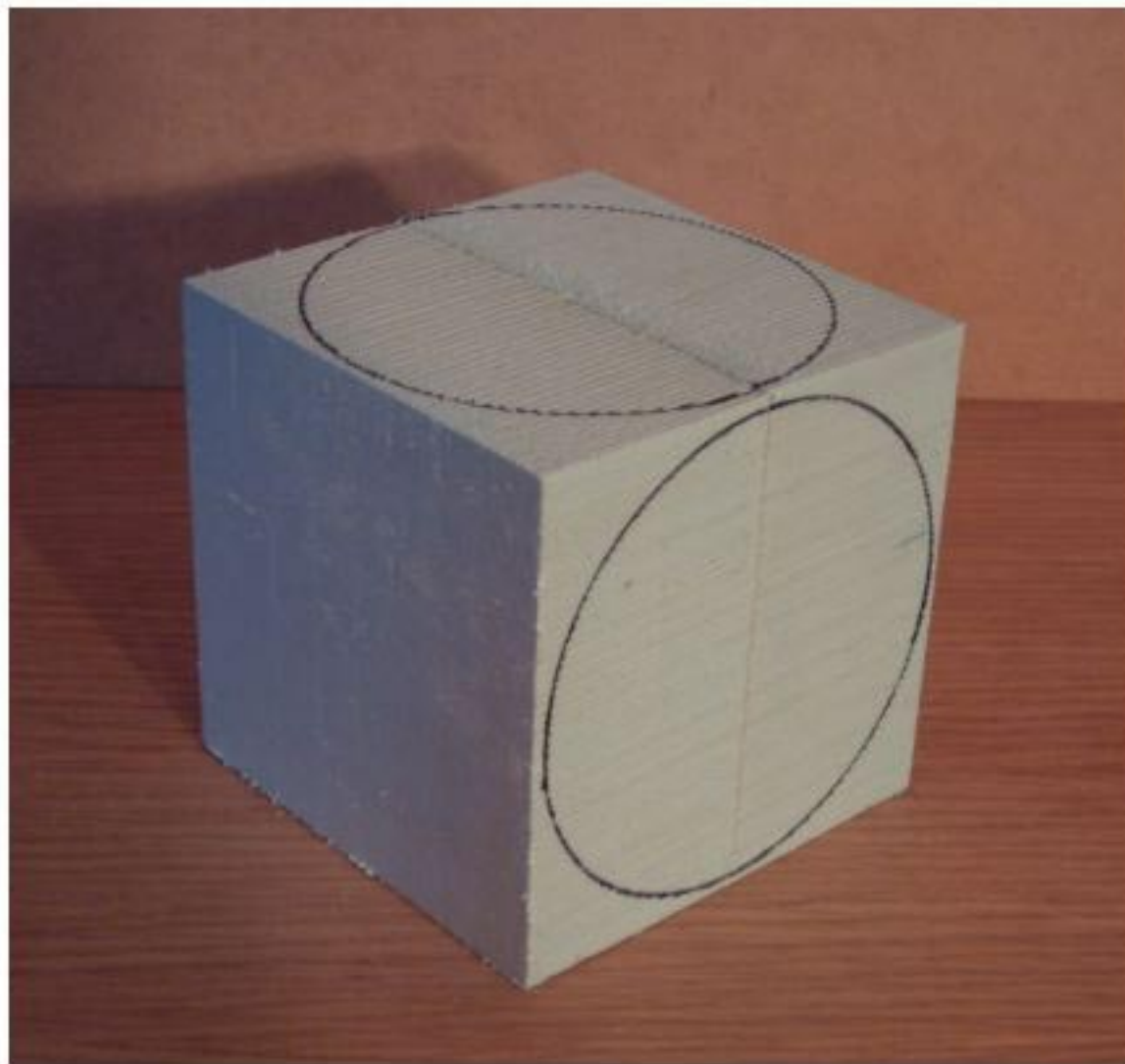

Solid 100mm Cube - No 8

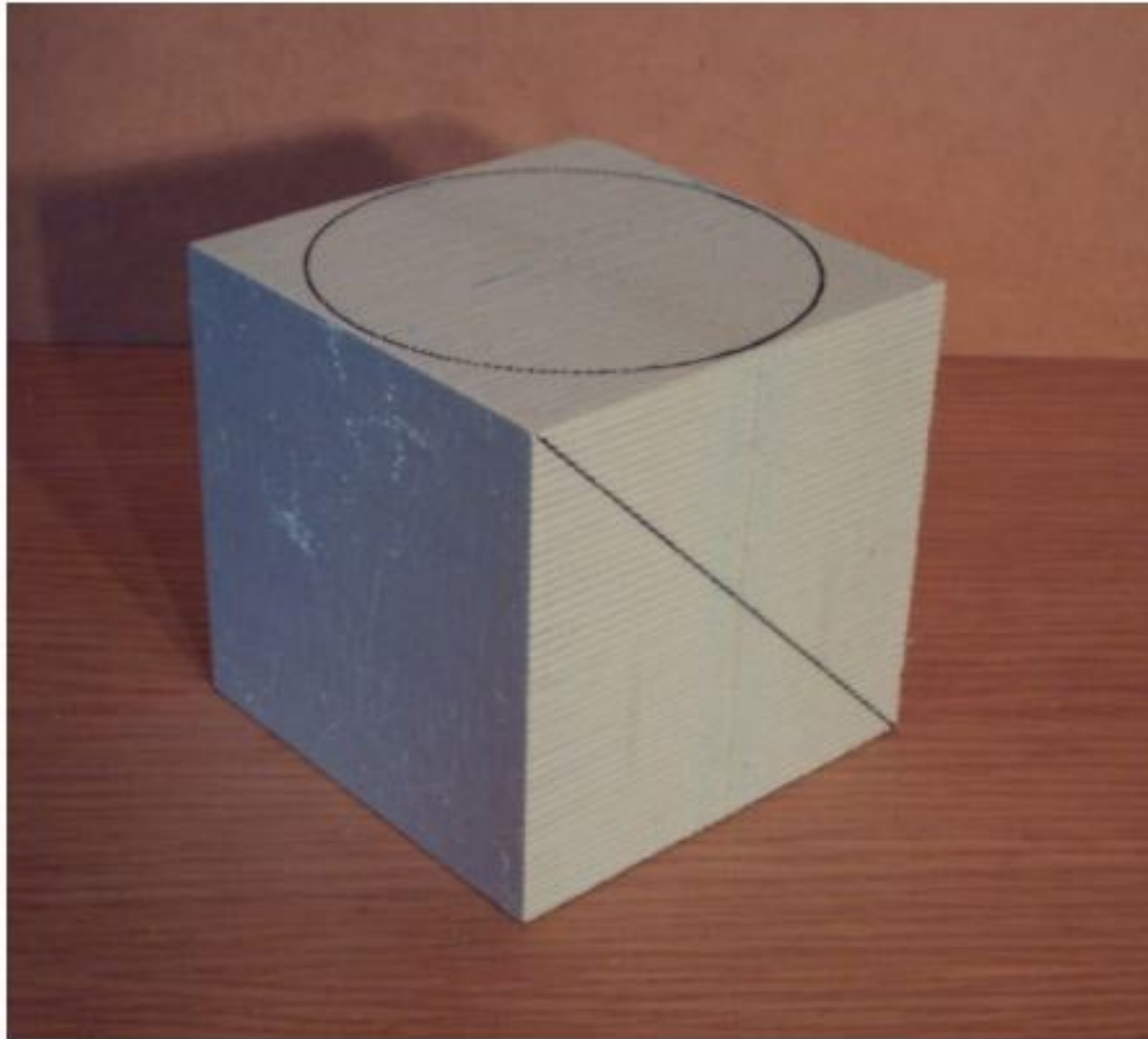

Solid 100mm Cube - No 9

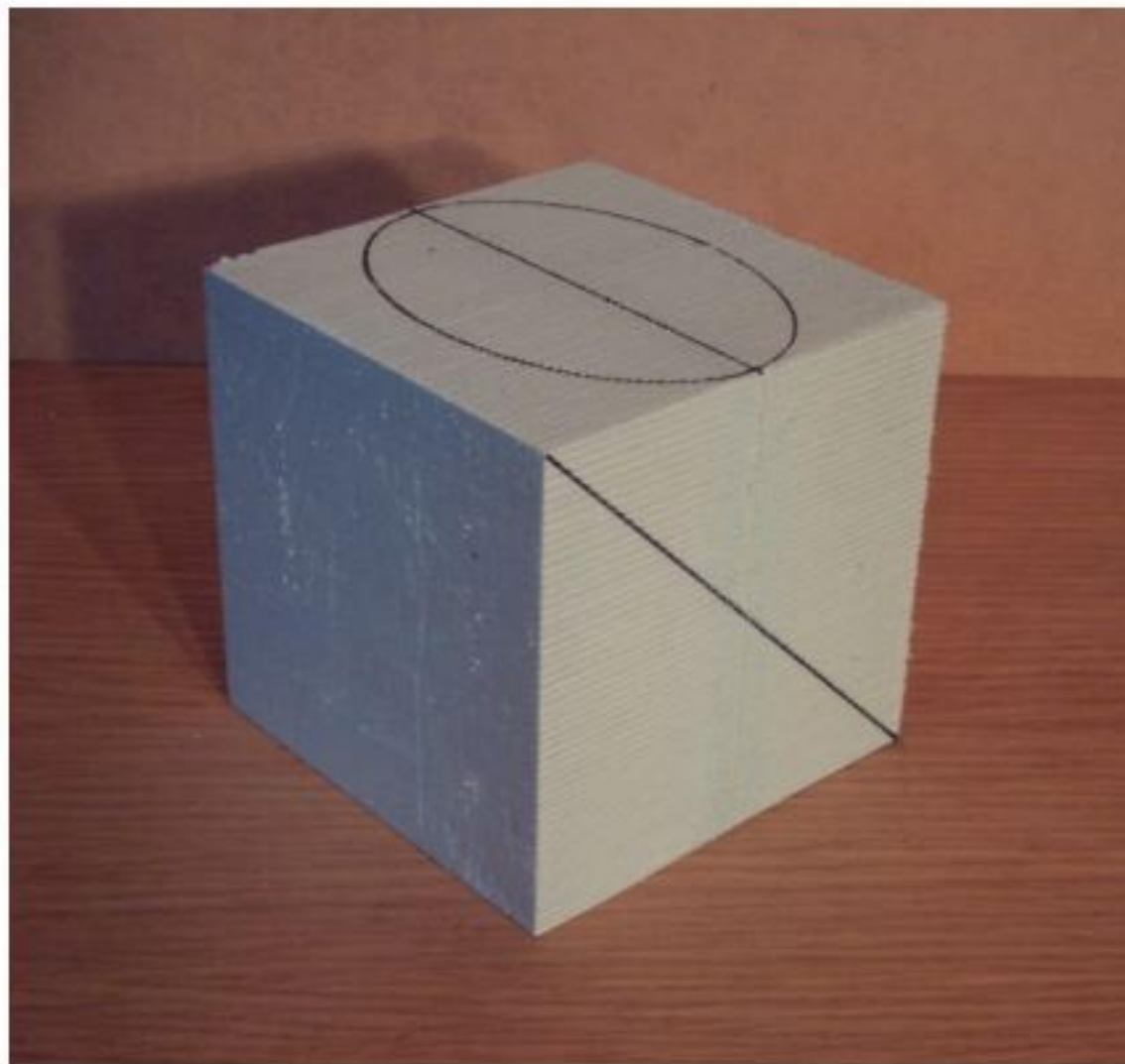

Slice through geometric solids

3-D shape

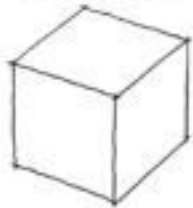

Vertical plane

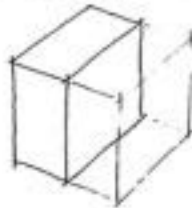

Horizontal plane



Inclined plane

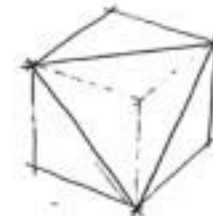
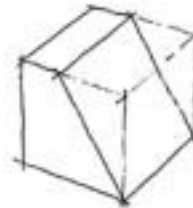

Circular plane

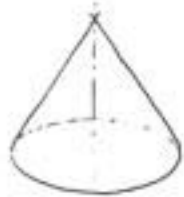
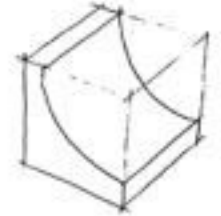

Hyperbola

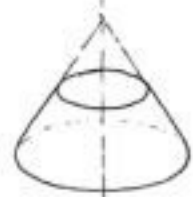

Circle

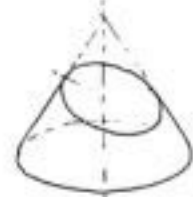

Ellipse

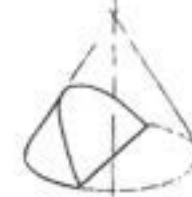

Parabola

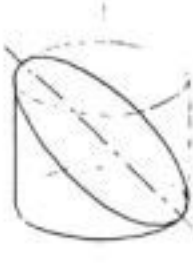
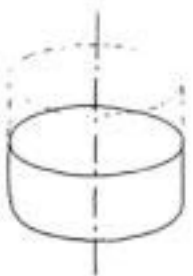
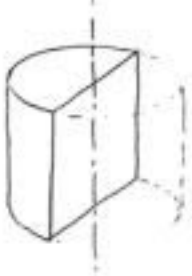
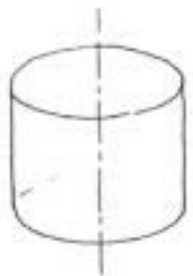
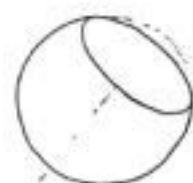
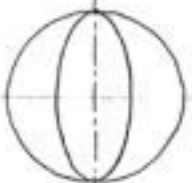
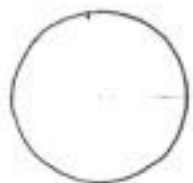

Interesting solids

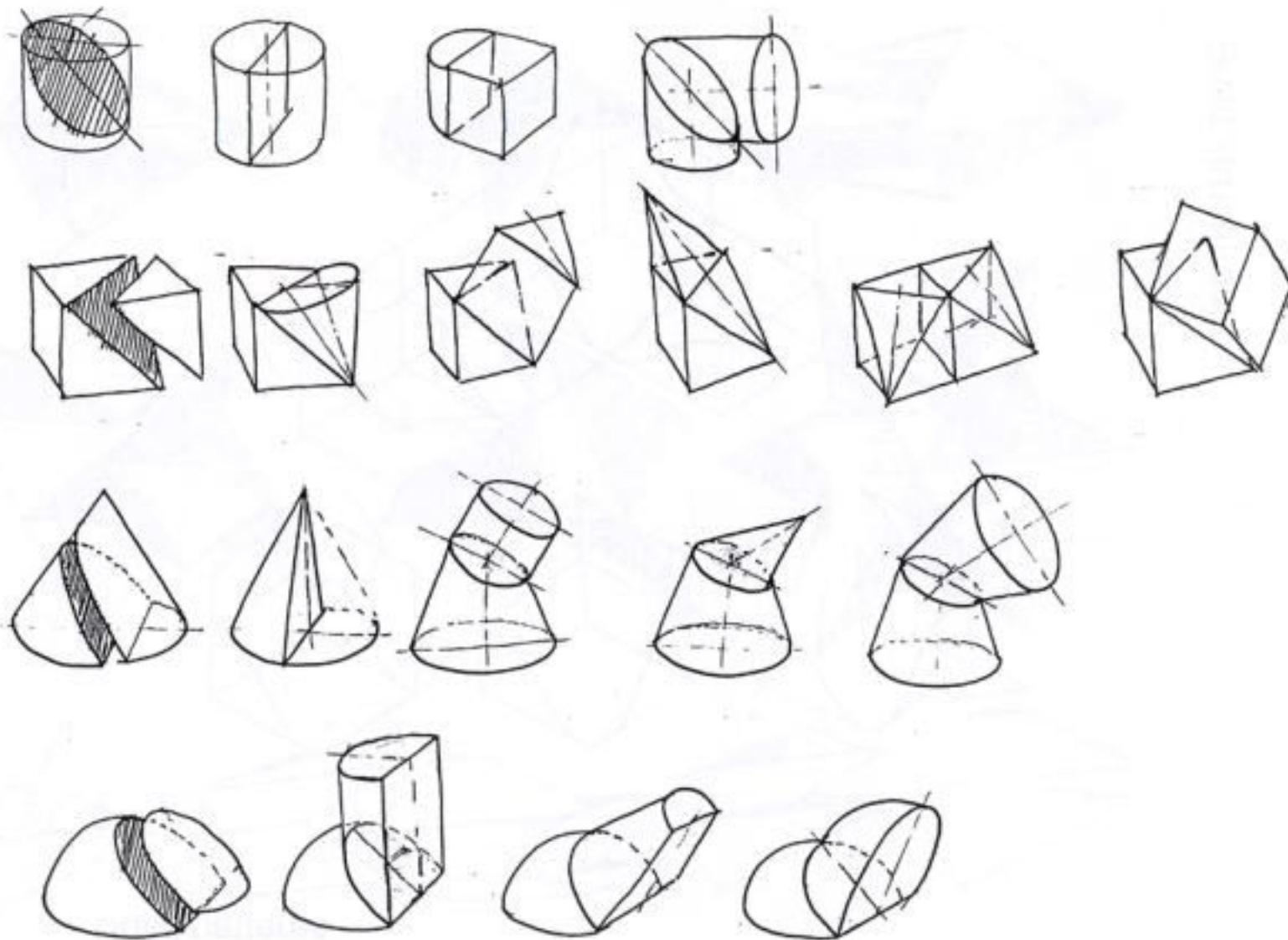

Build patterns

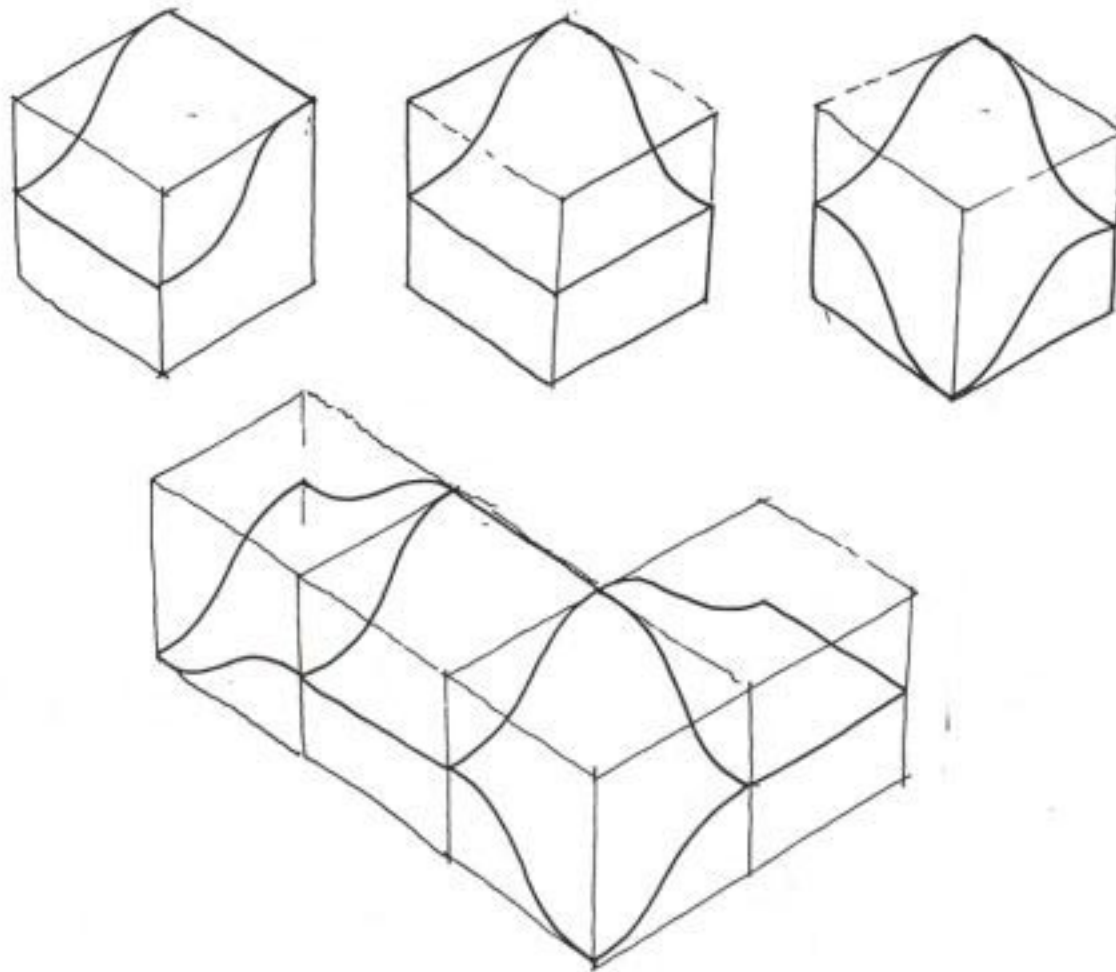

Build structures

